

HAWM2
HAWM2-CK
HAWM2-SMK

HAWM3
HAWM3-CK

Height Adjustable Wall Mount for Flat Panels

Assembly Guide



Check out our other products online at www.copernicused.com
For assistance, please contact us by telephone at **1-800-267-8494** or email at info@copernicused.com.
Have your packing slip ready for reference.

**! Wall mounting hardware is not included.
Installer must supply wall mounting hardware as specified in this guide.**

Shown with Flat Panel (sold separately).

HAWM2
(not compatible with cover)

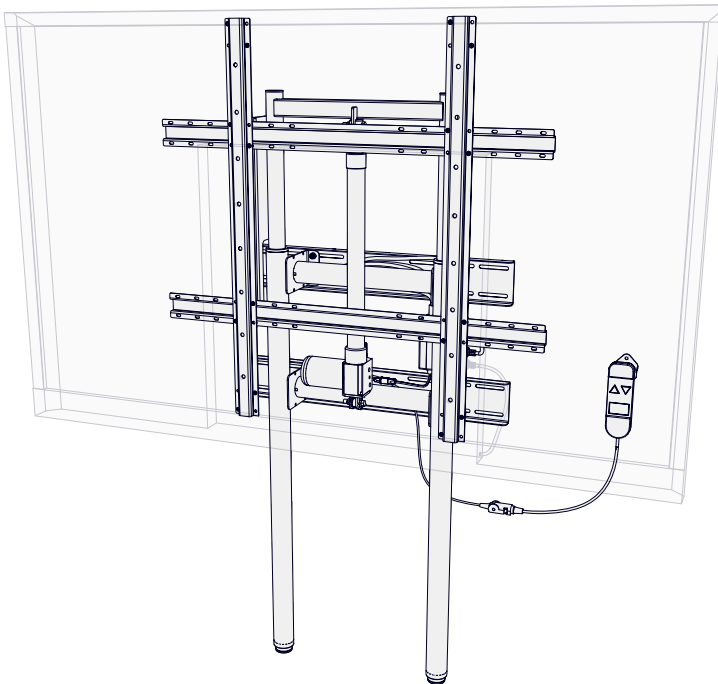

HAWM3
(with cover)

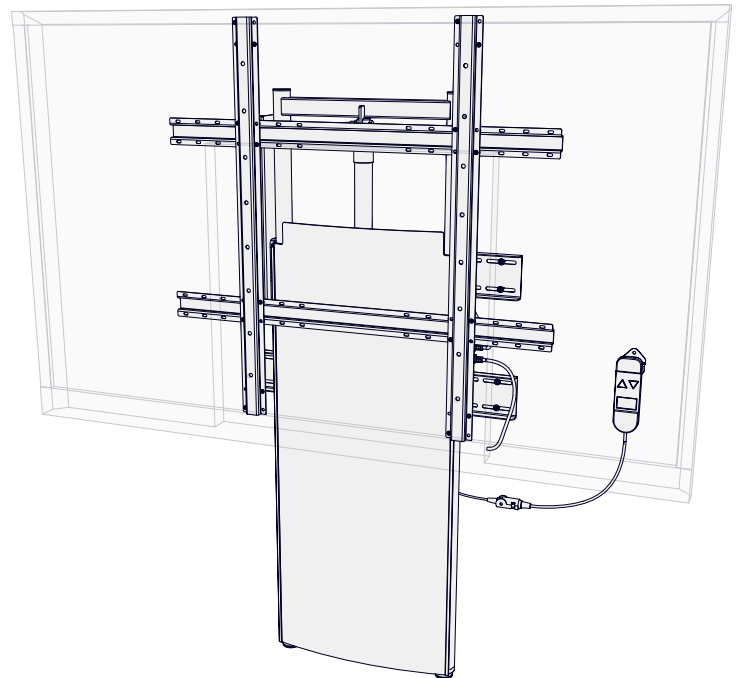

HAWM2-CK, HAWM3-CK - Conversion Kit
(showing HAWM2-CK)

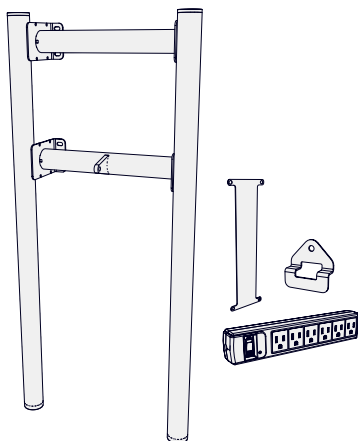

HAWM2-SMK - Stud Mounting Kit
(compatible with HAWM2, HAWM3)

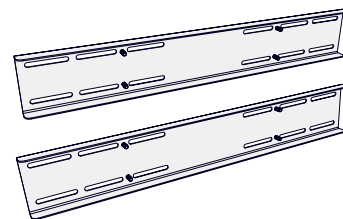

Please Recycle

Customer Service & Warranty Information

Dear Educator,

Thank you for purchasing the Height Adjustable Wall Mount for Flat Panels. We hope it meets your expectations and you and your students enjoy using it at your school.

Every day we see and hear stories of teachers going above and beyond to help students thrive. Thank you so much for all you do – you are awesome, and you make a difference.

Thank you for inspiring us.

If you have any questions, concerns or ideas on how we can improve please let us know by contacting our Customer Solutions Ninjas at 1-800-267-8494 or info@copernicused.com.

Happy teaching,

Kaylyn Belcourt, President
kaylyn@copernicused.com



We do not inherit the earth
from our ancestors, we
borrow it from our children.

- NATIVE AMERICAN PROVERB

Change is the end result of all
true learning.

- LEO BUSCAGLIA

What you leave behind is not
what is engraved in stone
monuments, but what is
woven into the lives of others.

- PERICLES

Education is the most
powerful weapon which you
can use to change the world.

- NELSON MANDELA

For missing parts and other issues regarding your product:

Please contact Customer Service, where we will be happy to help.
Telephone: 1-800-267-8494, Monday - Friday 8:00am - 4:30 pm EST
Email: info@copernicused.com

**Need Support?
Have a Question?**



Email [Customer Service](mailto:CustomerService)

**Check out some of our
other great products!**



www.copernicused.com

My flat panel isn't working, who should I call?

Please contact the reseller that you bought the product from.
Reseller information can be found on your packing slip.

Lifetime
Frame Warranty

Register your Product

Registering your warranty ensures we have all the information we need to make any future warranty claims quick and easy. Please visit www.copernicused.com/warranty and complete the form within 10 business days from product assembly. By registering your product, you will be entered into a draw to win Copernicus product.

Lifetime
All Components
Warranty

Make a Warranty Claim

We offer a Lifetime Warranty on almost everything we make. Please call **1-800-267-8494** or email info@copernicused.com to start your warranty claim. Proof of purchase will be required upon warranty claim (i.e. copy of invoice).

5 Year
Electric Lift
Warranty

Replace your Whiteboard

Have a well-used whiteboard that needs replacing? Our whiteboards carry a five-year warranty and replacement parts program after the warranty period. Please call **1-800-267-8494** or email info@copernicused.com to get a new whiteboard for your Copernicus product!

Tips for Assembly

Before You Begin:

- Lay out and identify all of the included parts.
- The hardware has been packed together in one bag.
- Read the assembly guide over once to familiarize yourself with them.

As You Assemble the Unit:

- Follow the steps in sequence.
- Before beginning each step, find the part(s) that you need for that step.
- The title of each step states what you will be doing. Review the text and the pictures as you build the unit.

Watch for These Helpful Symbols:



2-Person Task

For safety, please have someone help you when working on steps displaying this symbol.



The symbol denotes a step needing extra attention to ensure it is done correctly.



Important Information! Warning!

Please read the warnings below for important safety information regarding your product. Failure to read these warnings or to follow the instructions below could result in personal injury or damage to your product that could void your warranty.



Small Parts

In its unassembled state, this product contains parts that can be hazardous to small children. This product should be assembled by an adult.



Adult Supervision

This product is to be used under the supervision of an adult.



Climb Hazard

Do not climb on, hang from or suspend objects from any components of your product unless otherwise specified.



Indoor Use Only

This product is intended for indoor commercial use only. To reduce the risk of fire or electric shock, do not expose this product to rain or moisture. The internal components are not sealed from the environment.



Power Strip Specifications

Read your power strip electrical specifications. Only plug in devices that are approved for use with this power strip. Connect the supplied power strip directly to a wall outlet. **Do not connect to another power strip or use an extension cord.** Turn off power strip before unplugging. Unplug when not in use.



Electronic Equipment

Read the electrical specifications of any electronic equipment you are using with your Copernicus products. Failure to read these specifications and follow their instructions could result in damage to your equipment or personal injury.



Cable Trip Hazard

Ensure that any cables extending across the floor to your product are properly bundled and marked to avoid tripping or falling which may lead to personal injury.



Electrical Shock

Do not install or use the electrical components of this unit during a lightning storm.

Parts: HAWM2 / HAWM3

Before beginning, you should have:

Additional tools required:

Adjustable Wrench **2x**
Or
9/16" Wrench **2x**



+

Screwdriver
+ Phillips #2



+

Level **1x**

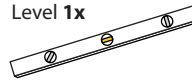

+

Hammer Drill **1x**



IFP500-1

Moving Frame
(33161)
1x

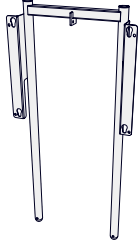

Flat Panel Mount Riser
(33149)
2x

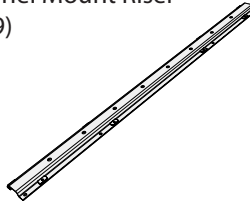

Flat Panel Mount Stretcher
(33148)
2x

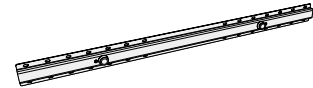

HAWM2-0

Main Wall Bracket
(51120)
1x

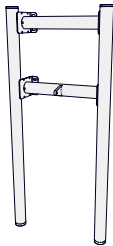

Electric Lift & Remote
(25525)
1x

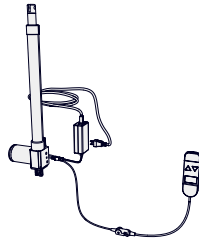

OR

Power Strip
Mounting Plate
(32364)
1x



Remote Hanger
Bracket
(34099)
1x

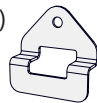

Power Strip
(255153)
1x



Hardware Inside

HAWM3-0

Main Wall Bracket with Cover
(51121)
1x

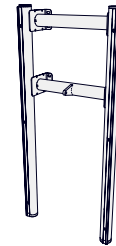

Electric Lift & Remote
(25525)
1x

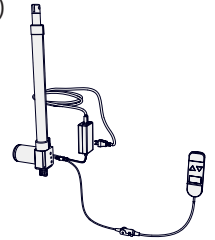

Power Strip
Mounting Plate
(32364)
1x



Remote Hanger
Bracket
(34099)
1x

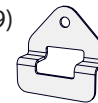

Power Strip
(255153)
1x



Cover
(36000)
1x



Hardware Inside















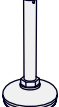

...hardware on following page

Parts: HAWM2 / HAWM3

...continued

Hardware

Actual Size

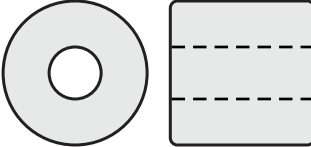
- | | | | |
|--|--|---|--|
| <p>(A) 3/8" x 1-3/4" Bolt
(430204)
2x</p>  | <p>(F) 3/8" Lock Nut
(430122)
2x</p>  | <p>(J) 1-4" Flat Washer
(430192)
8x</p>  | |
| <p>(B) 1/4" x 3/4" Self Tapping Screw
(4300510)
4x</p>  | <p>(G) 5/16" Lock Washer
(43025)
4x</p>  | <p>Levelling Foot
(not to scale)
(42107)
2x</p>  | |
| <p>(C) #6-32 x 3/8" Screw
(4301352)
4x</p>  | <p>(D) #10-24 x 1/2" Self Tapping Screw
(4302012)
8x</p>  | <p>Hook & Loop Tape (not to scale)
(43322 / 43323)
3x / 3x</p>  | |
| <p>(E) #6-32 Keps Nut
(430154)
4x</p>  | <p>(H) 1/4" Lock Washer
(43010)
8x</p>  | <p>Hook & Loop Straps
(not to scale)
(433211)
3x</p>  | |
| <p>(I) #10-24" Lock Washer
(4301002)
8x</p>  | | | |
| <p>(K) M6 x 15mm VESA Screw
4x
(432151)</p>  | <p>(L) M6 x 20mm VESA Screw
4x
(43222)</p>  | <p>(M) M8 x 15mm VESA Screw
4x
(432764)</p>  | |
| | | | <p>(N) M8 x 25mm VESA Screw
4x
(432765)</p>  |
| <p>(O) M8 x 40mm
4x
(432762)</p>  | <p>(P) 3/4" Spacer
4x
(4303141)</p>  | | |

Parts: HAWM2-CK / HAWM3-CK *(IFP500 required)*

HAWM2-CK

Main Wall Bracket
(51120)
1x

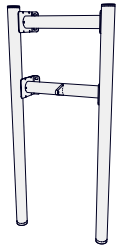

Power Strip Mounting Plate
(32364)
1x



Remote Hanger Bracket
(34099)
1x

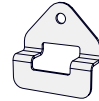

Power Strip
(255153)
1x

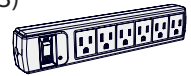

Hardware Inside

OR

HAWM3-CK

Main Wall Bracket
with Cover
(51121)
1x

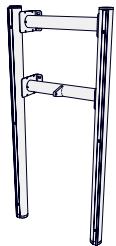

Cover
(36000)
1x



Power Strip Mounting
Plate
(32364)
1x

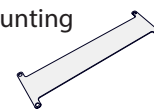

Remote Hanger Bracket
(34099)
1x

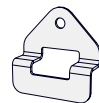

Power Strip
(255153)
1x



Hardware Inside

Hardware Actual Size

C #6-32 x 3/8" Screw
(4301352)
4x



E #6-32 Keps Nut
(430154)
4x



J 1-4" Flat Washer
(430192)
8x

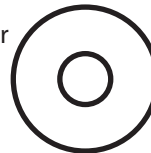

Levelling Foot (not to scale)
(42107)
2x

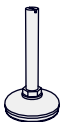

Hook & Loop Tape (not to scale)
(43322 / 43323)
3x / 3x



Hook & Loop Straps (not to scale)
(433211)
3x

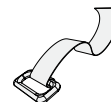

Parts: HAWM2-SMK *(Optional Accessory)*

HAWM2-SMK

Wood Stud Mounting Bracket
(32362)
2x

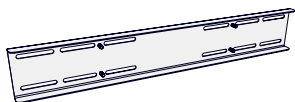

Inside

Q 1/2" Lock Nut
(430101)
8x



J 1-4" Flat Washer
(430192)
8x

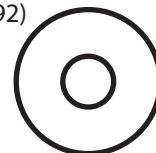

Additional Hardware Required (not included)

Masonry Wall Installation

Minimum specifications (per fastener):

Masonry Screws 8x

Shear: 200lbs (91kg)

Tension: 150lbs (68kg)

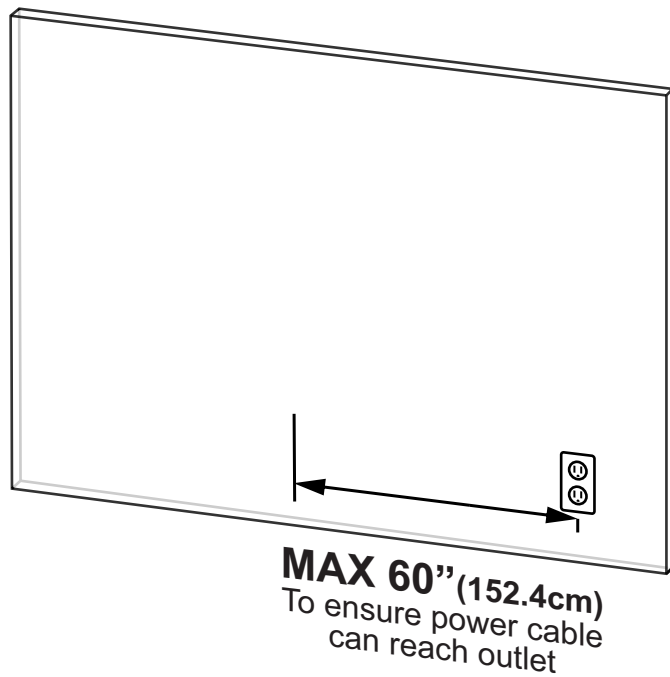
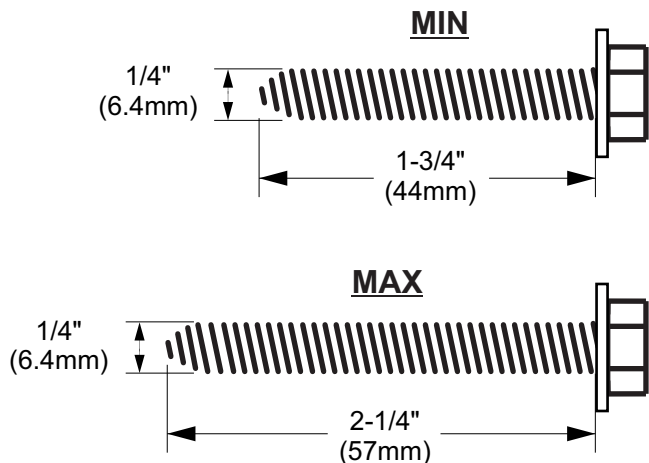

OR

Wood Stud Wall Installation (HAWM2-SMK required)

Minimum specifications (per fastener):

Lag Screws 8x

Shear: 200lbs (91kg)

Tension: 150lbs (68kg)

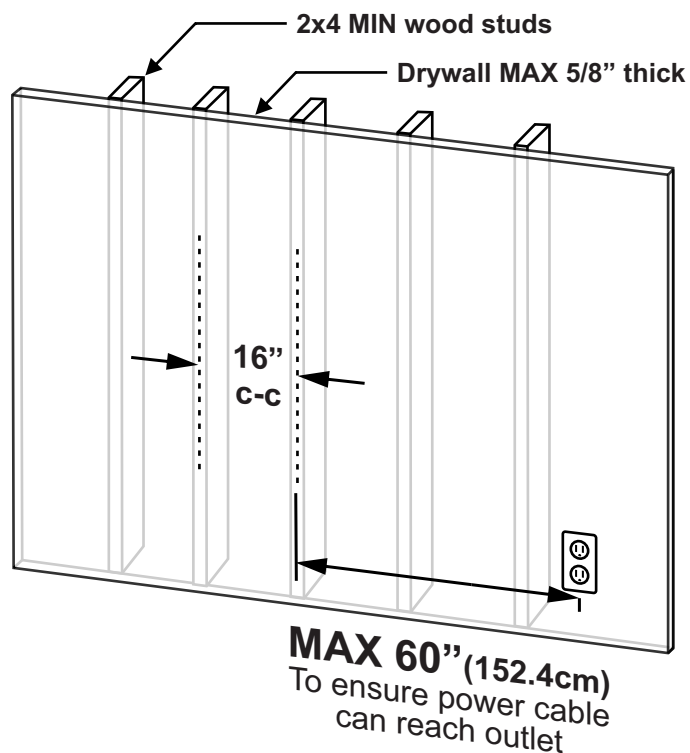
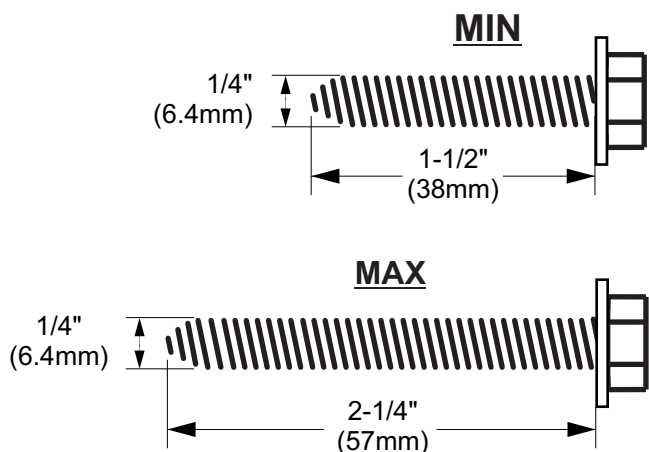



For converting an IFP cart to a wall mount using the conversion kit HAMW2-CK or HAWM3-CK, follow these steps first. If you are installing a new complete HAWM2 or HAWM3 wall mount skip to page 9.

CK-1



2-Person Task

You Will Need: (Actual Size)



You will need: (Not to Scale)

Screwdriver



Remove Safety Screws and Flat Panel From Cart

! Save the hardware and set flat panel aside in a safe place, you will need it later for Step 12

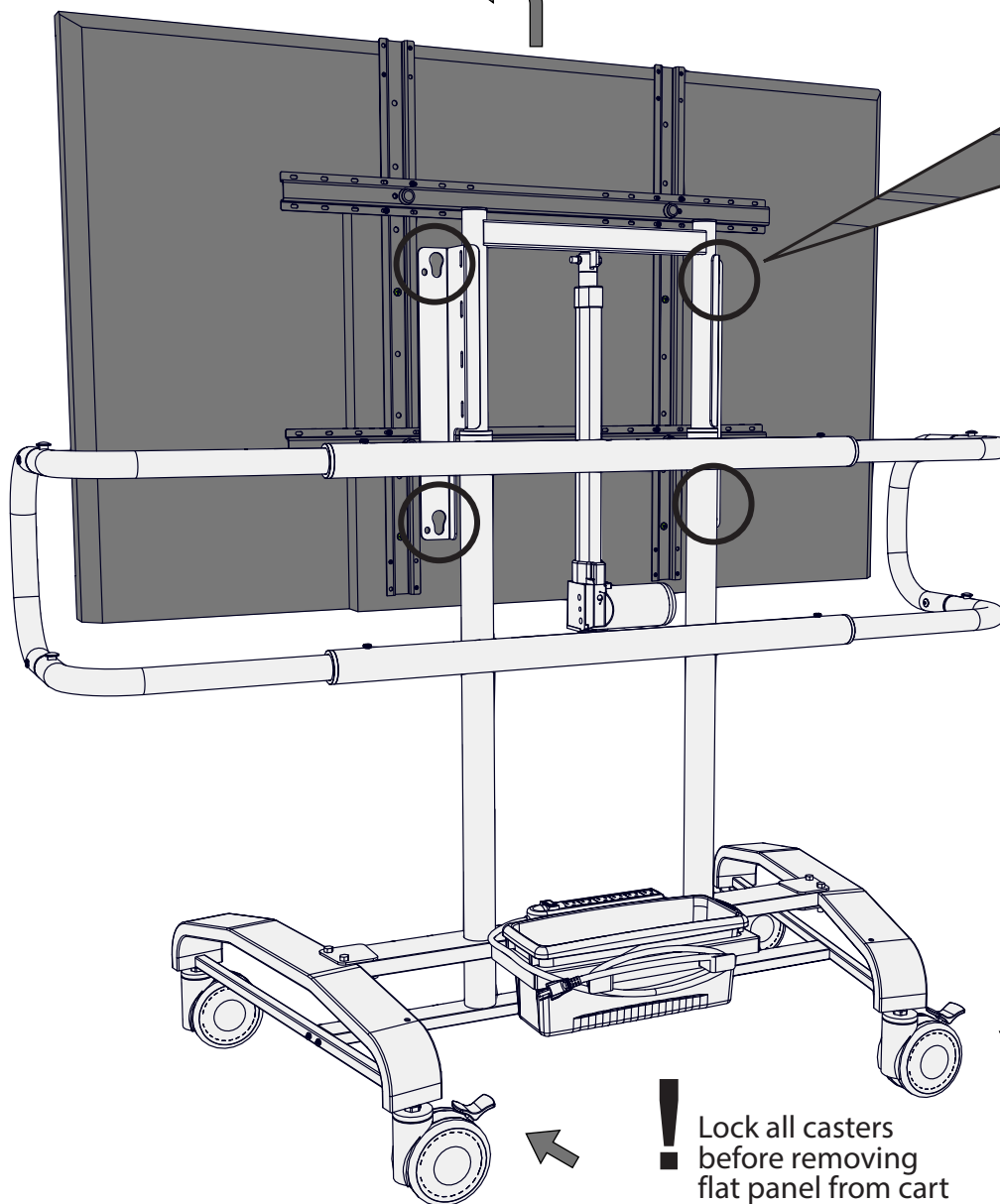

1 Remove all 4 Safety Screws

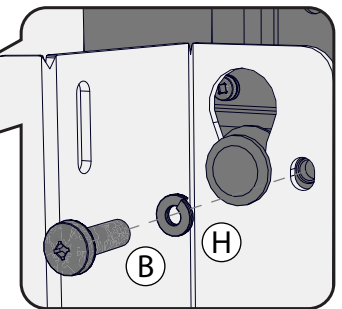

2 Lift up and pull out all 4 adapters from keyholes

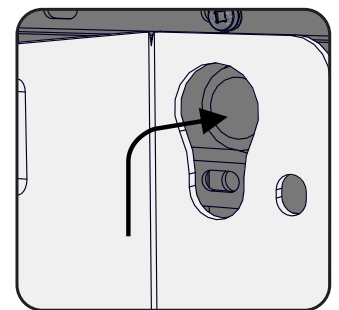

! Lock all casters before removing flat panel from cart

CK-2

You Will Need: (Actual Size)

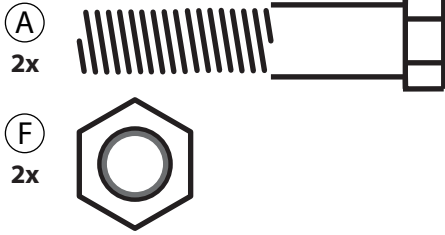

You will need: (Not to Scale)

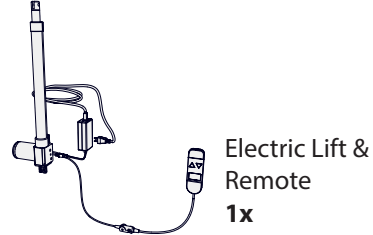

Remove Electric lift

! Save the hardware,
you will need it later for Step 5

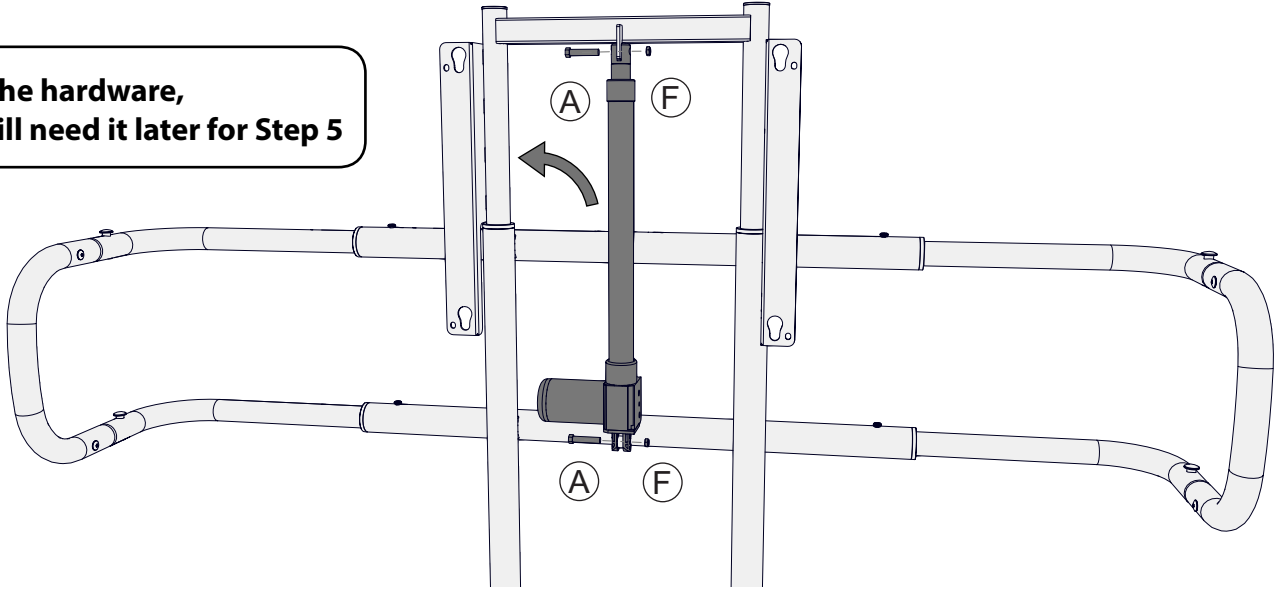

CK-3

You will need: (Not to Scale)

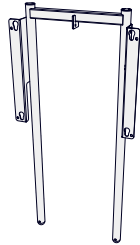

Moving Fame
1x

Remove Moving Frame

! Save the Moving Frame,
you will need it later for Step 2

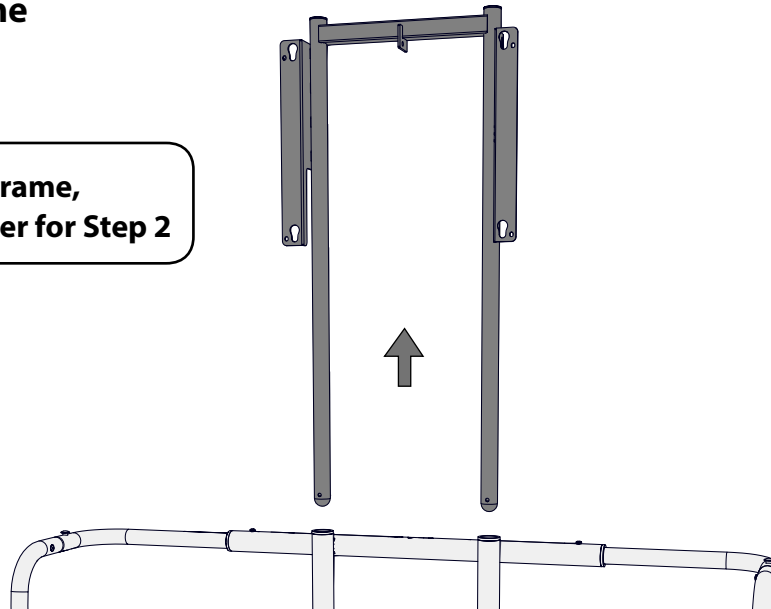



Note For Installation

WARNING:

The bottom edge of the flat panel must be 20" (50.8cm) or more off the floor when the HAWM is in the fully lowered position!

You can install the flat panel higher up on the mount if needed. (See Step 10)

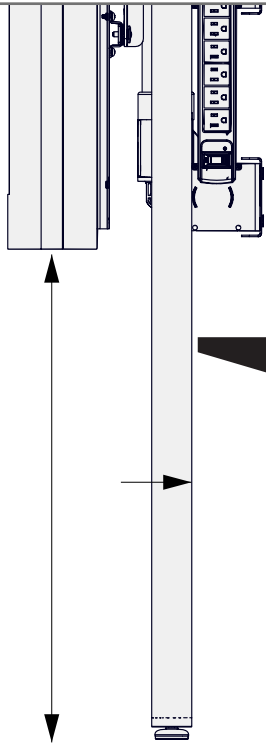

WARNING:

Do not mount the HAWM over a marker ledge that is deeper than 3-3/8" (86mm).

1

You will need: (Not to Scale)

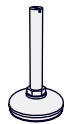

Levelling Feet
2x



Main Wall Bracket
1x

Remove Cover (HAWM3) & Install Levelling Feet

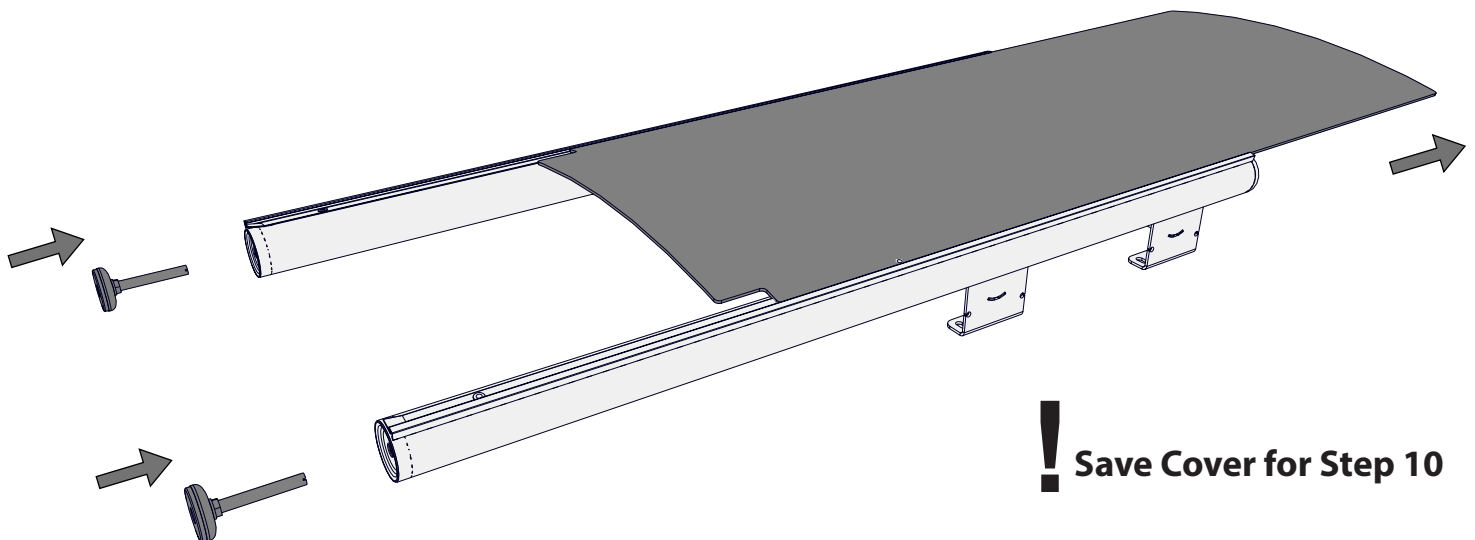

! Save Cover for Step 10

2

You will need: (Not to Scale)



2-Person Task

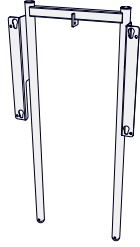

Moving Frame
1x

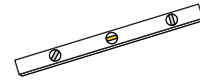

Level
1x

Level Moving Frame Before Installing On Wall

1

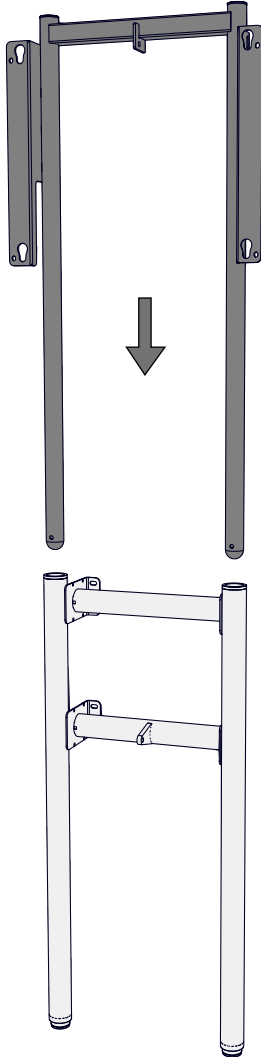

2

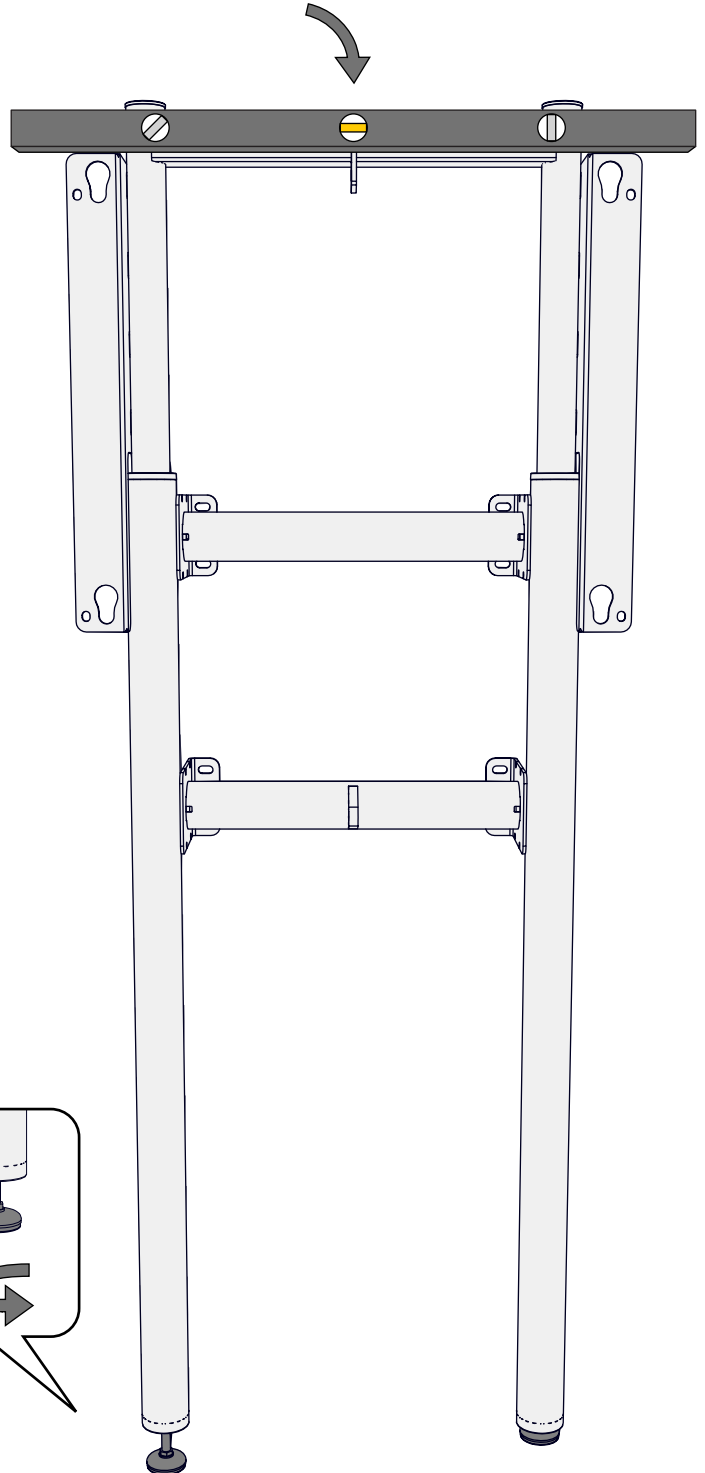

! Position against wall in the location where the mount will be installed

3

Actual Size:



You will need: (Not to Scale)



Hammer Drill
1x

Masonry Wall Installation: Pre-drill Holes Into Wall and Secure with Fasteners

- ! Use hardware recommended for your wall type.
 - See Page 6 for recommended hardware.
 - Use the supplied flat washers.
- FASTENERS ARE NOT INCLUDED.**



...For Wood Stud Wall Installation go to Step 4



4

Actual Size:



You will need: (Not to Scale)

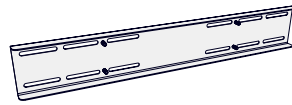

Wood Stud Mounting Bracket
2x



Hammer Drill
1x

Wood Stud Wall Installation: Pre-drill Holes Into Wall Studs and Secure with Fasteners

1. Position stud bracket on main wall bracket. Do not fasten yet
2. Mark holes where slots in bracket intersect wall studs (at least two studs)
3. Remove both brackets from wall and pre-drill pilot holes
4. Secure wall bracket to wall
5. Secure main bracket to wall bracket

...For Masonry Wall Installation go to Step 3

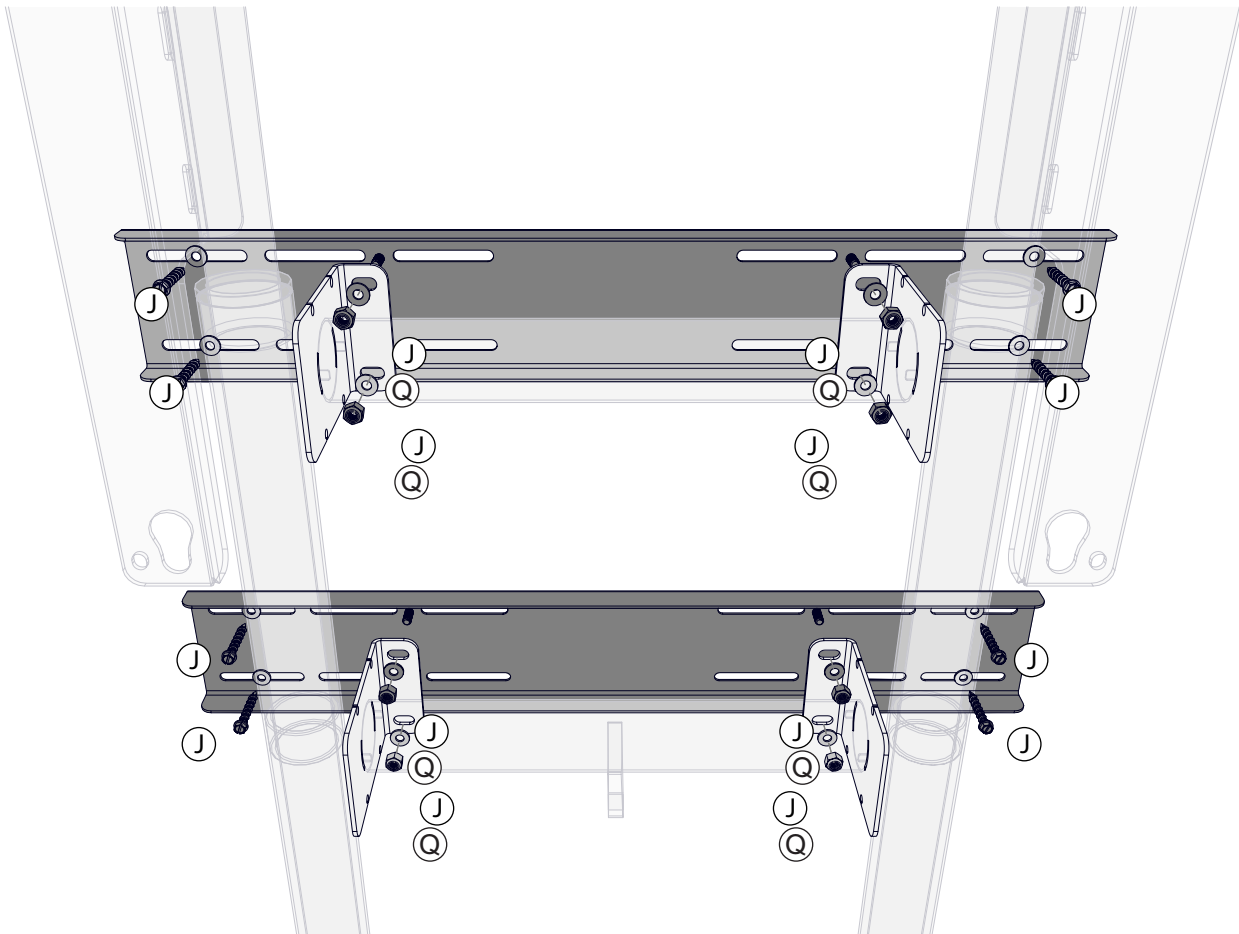

! Use hardware recommended for your wall type.
■ See Page 6 for recommended hardware.
 Use the supplied flat washers.
FASTENERS ARE NOT INCLUDED.



5

Actual Size:

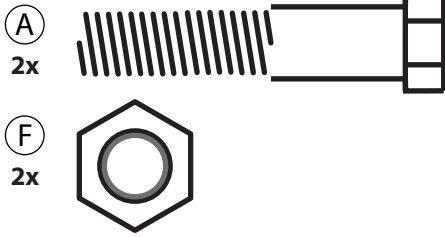

You will need: (Not to Scale)

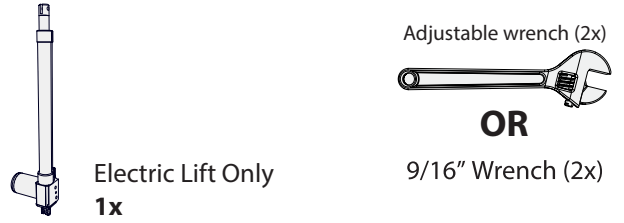

Install Electric Lift

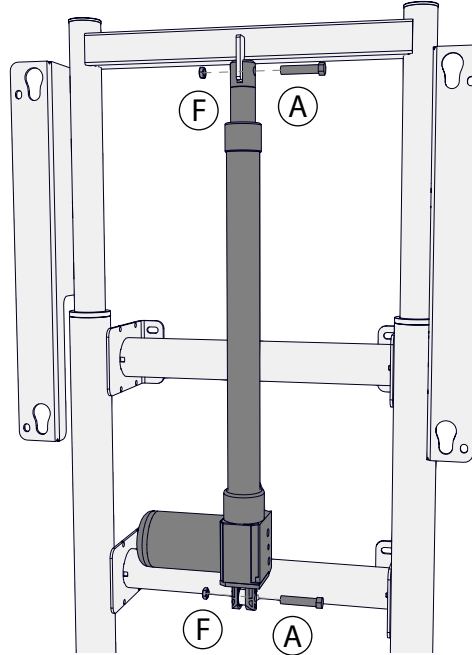

6

Actual Size:

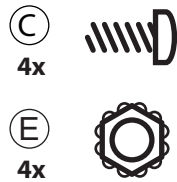

You will need: (Not to Scale)

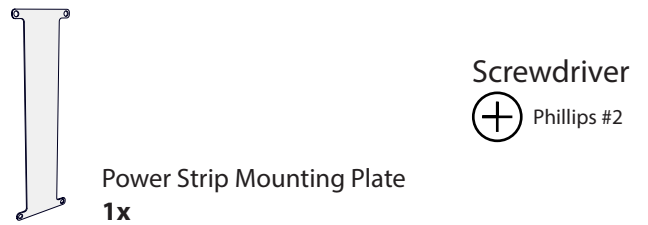

Install Power Strip Mounting Plate

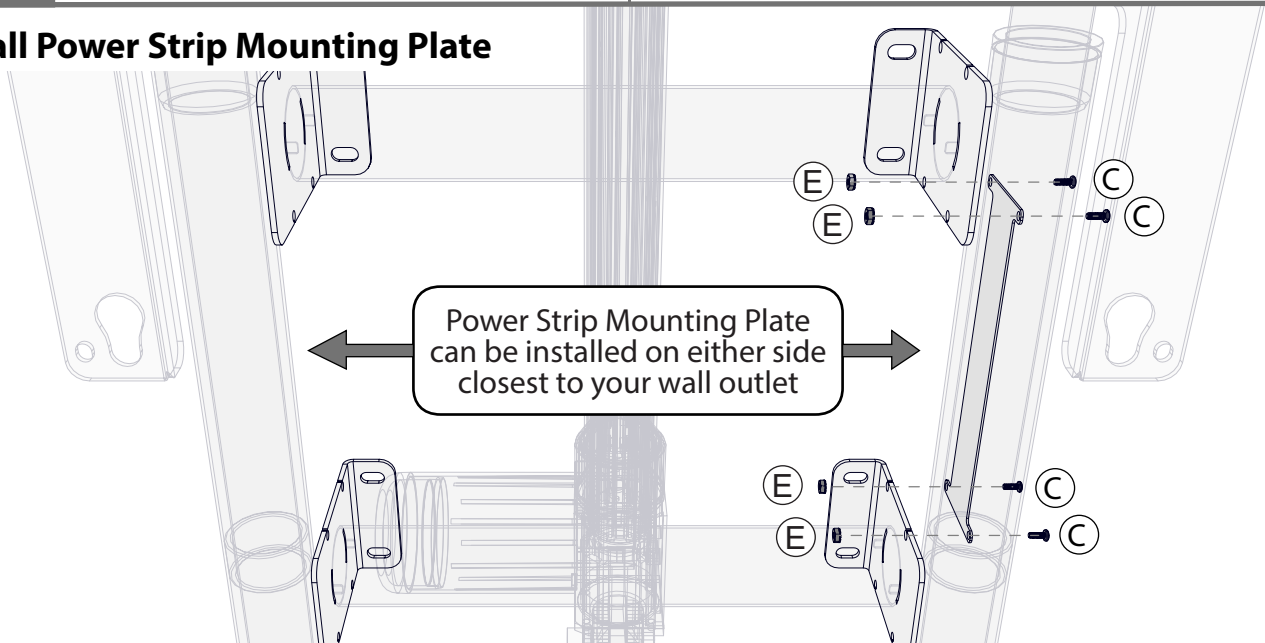

7

You will need: (Not to Scale)

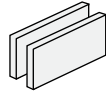

Hook & Loop Tape
2x / 2x

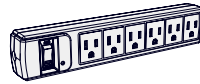

Power Strip
1x

Attach Power Strip

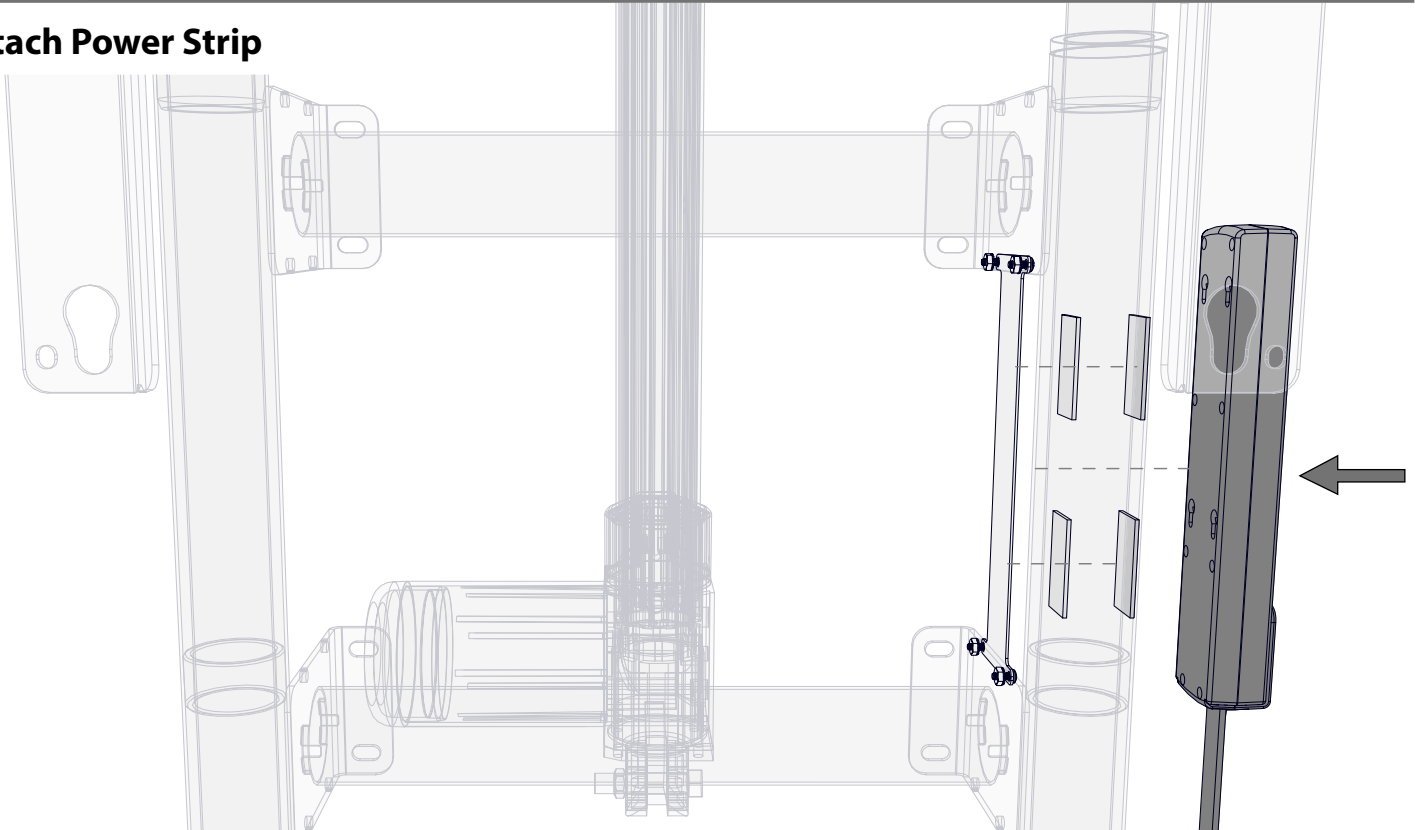

8

You will need: (Not to Scale)

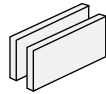

Hook & Loop Tape
1x / 1x



Electric Lift Power Adapter
1x

Attach Electric Lift Power Adapter

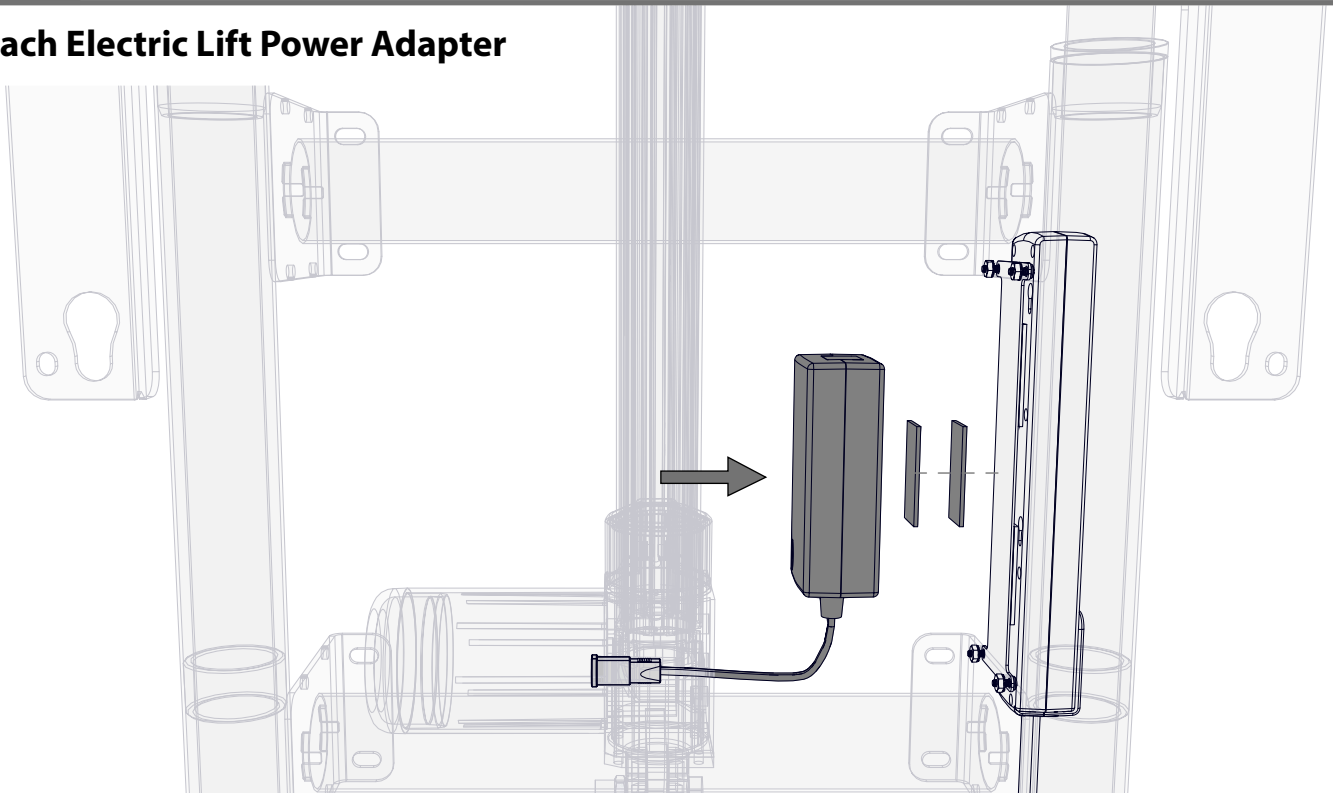

9

You will need: (Not to Scale)



Hook & Loop Straps
2x

Attach All Electric Lift Cables & Secure With Straps

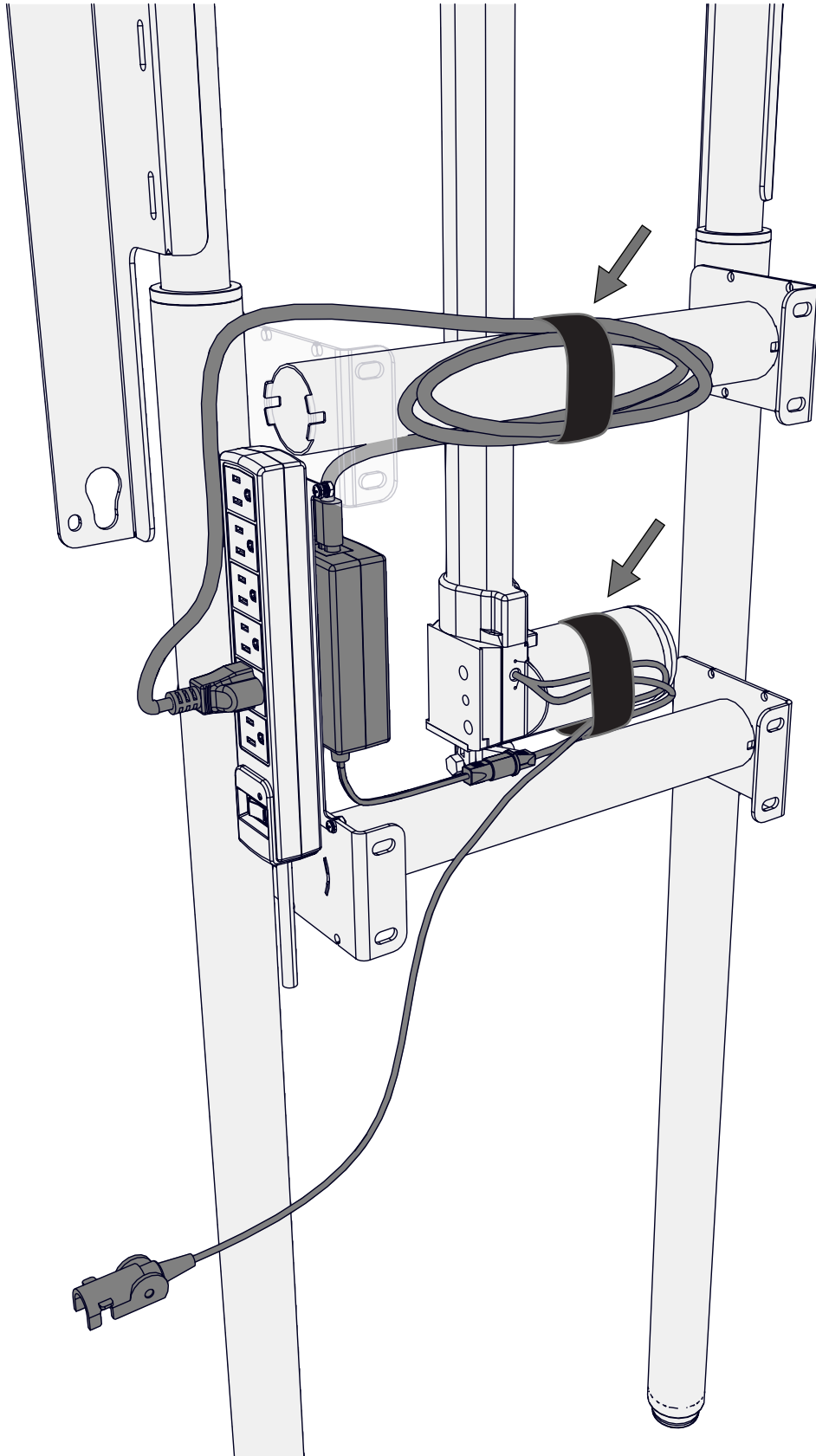

10

You will need: (Not to Scale)

HAWM3,
HAWM3-CK
ONLY



Cover
1x

For HAWM3 & HAWM3-CK Install Cover (Otherwise Skip Step)

1 Remove Moving Frame (save top fasteners).

2 Slide in cover from top.

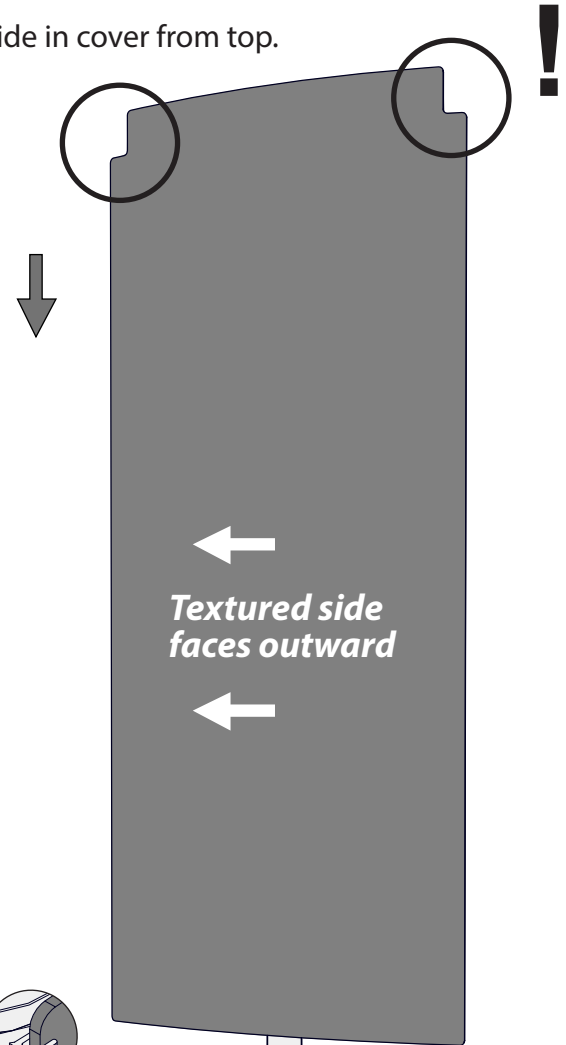
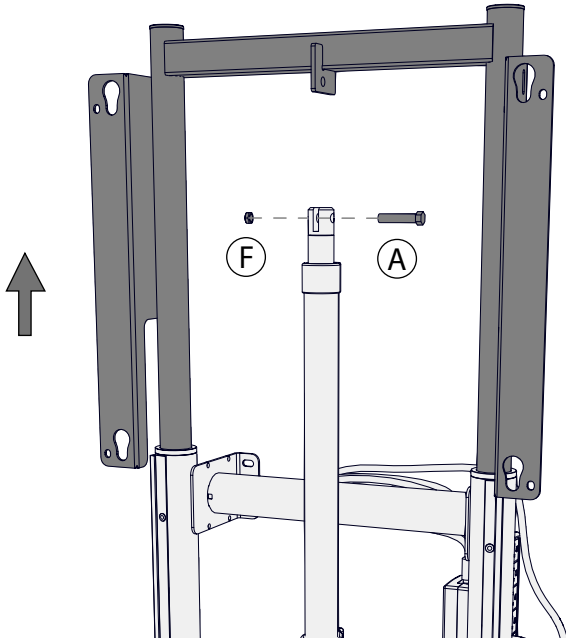

3 Reinstall Moving Frame & Hardware.

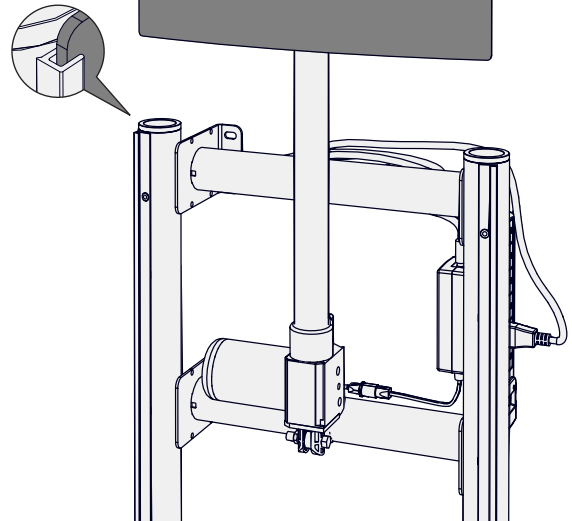
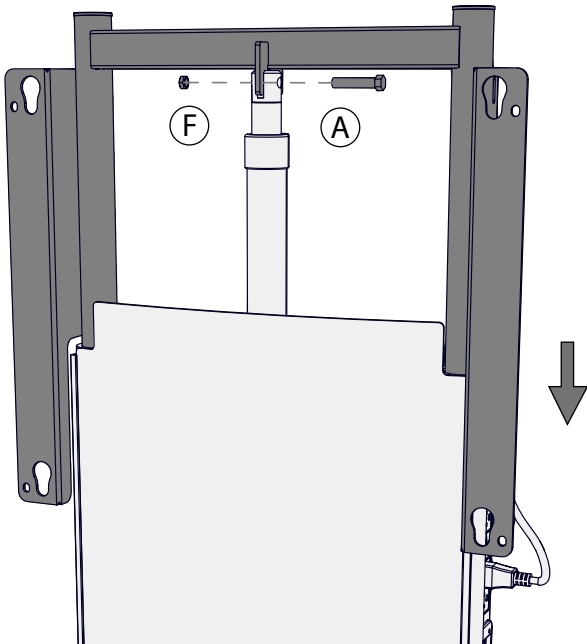

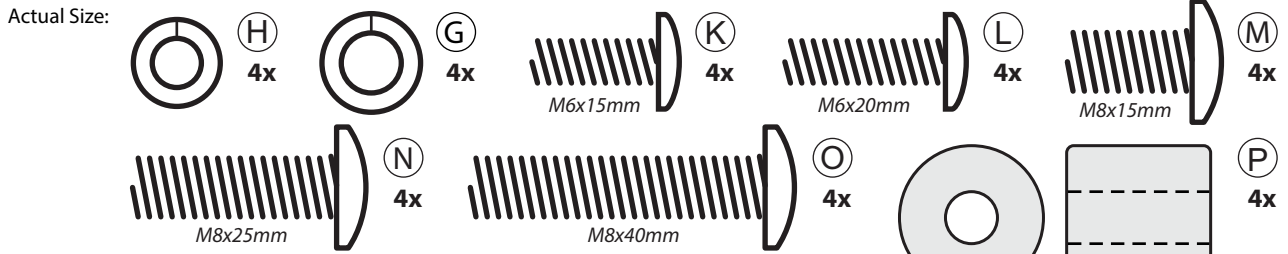

You will need: (Not to Scale)

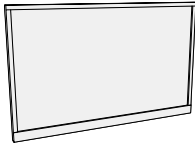

Compatible flat panel
(sold separately)
1x

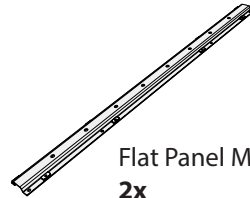

Flat Panel Mount Riser
2x

Screwdriver
⊕ Phillips #2

Attach Flat Panel Mount Risers to Flat Panel

! Check your flat panel owners manual to determine correct VESA screw size and torque specifications to avoid causing damage to your flat panel.

(Showing SMART MX265 Flat Panel)

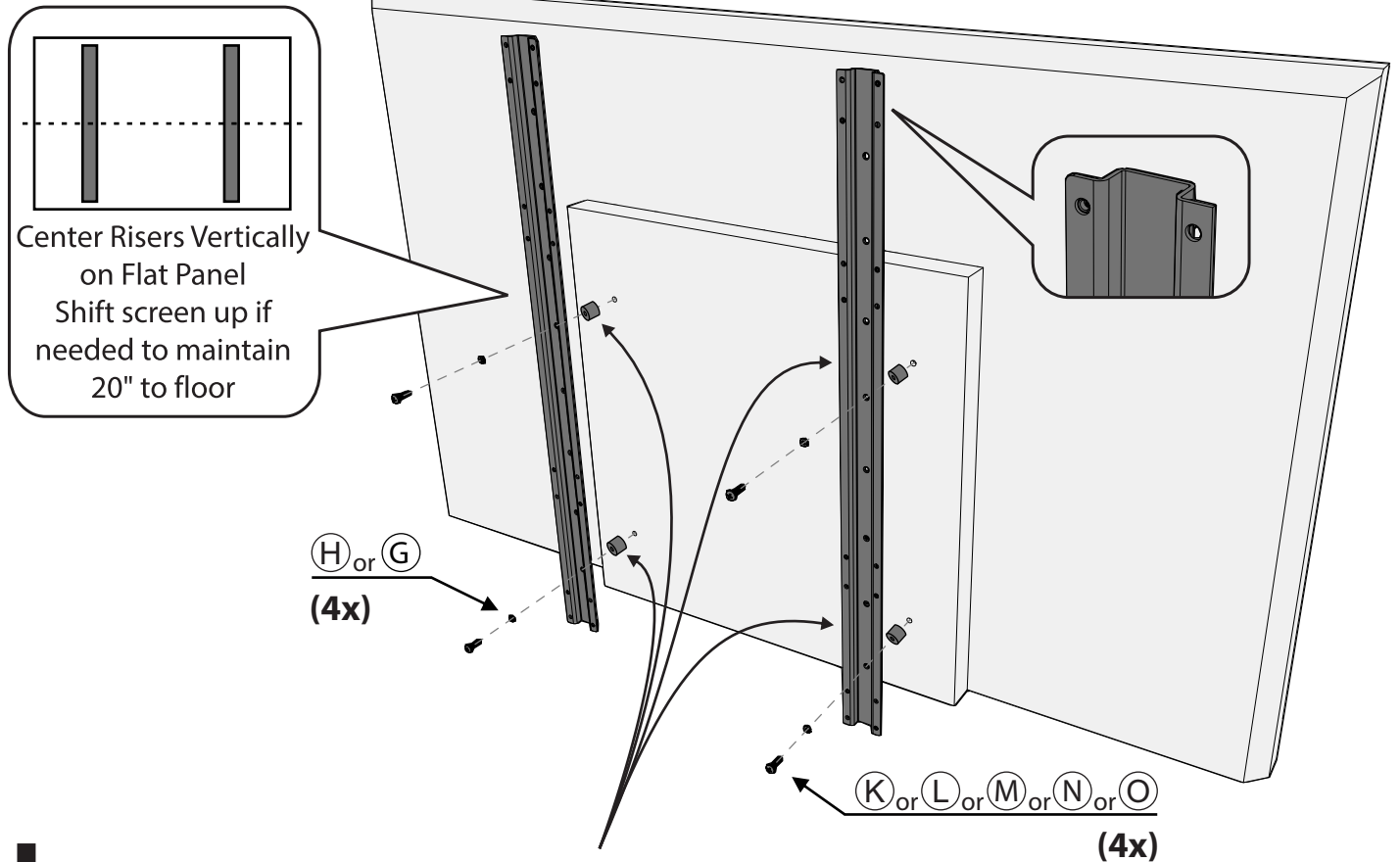

! For TVs without a flat back (Ex. Promethean) use the provided 3/4" spacers and longer screws. Install spacers between mount and TV.

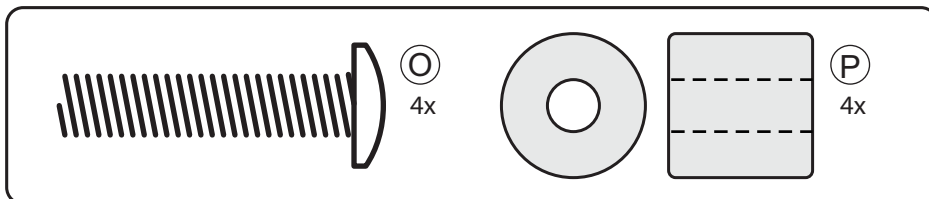

12

Actual Size:



You will need: (Not to Scale)

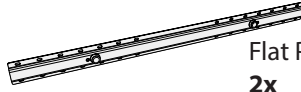

Flat Panel Mount Stretcher
2x

Screwdriver



Install Flat Panel Mount Stretchers

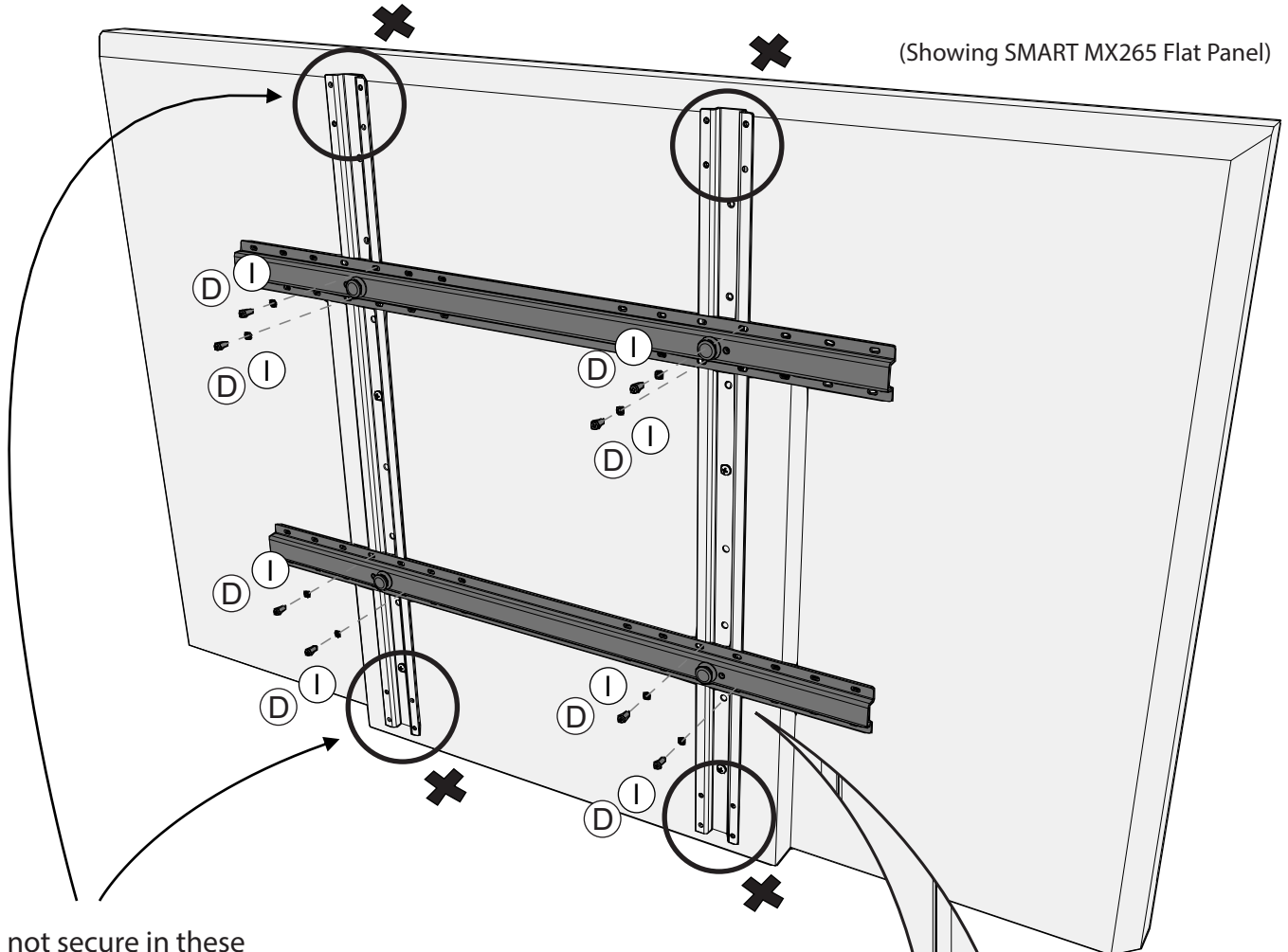

! Do not secure in these holes, they are used for attaching an optional soundbar mount

! Install screws in holes with threads, only 2 of 4 holes will have threads

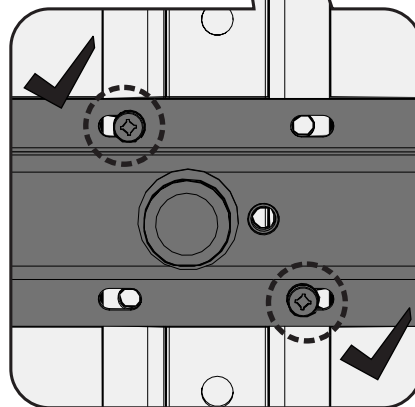

13



2-Person Task

Actual Size:



You will need: (Not to Scale)

Screwdriver



Attach & Secure Flat Panel to Wall Mount

Showing with HAWM2 Version

- 1 Insert all 4 adapters into keyholes.

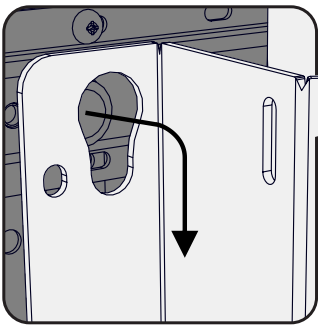

- 2 Insert all 4 Safety Screws

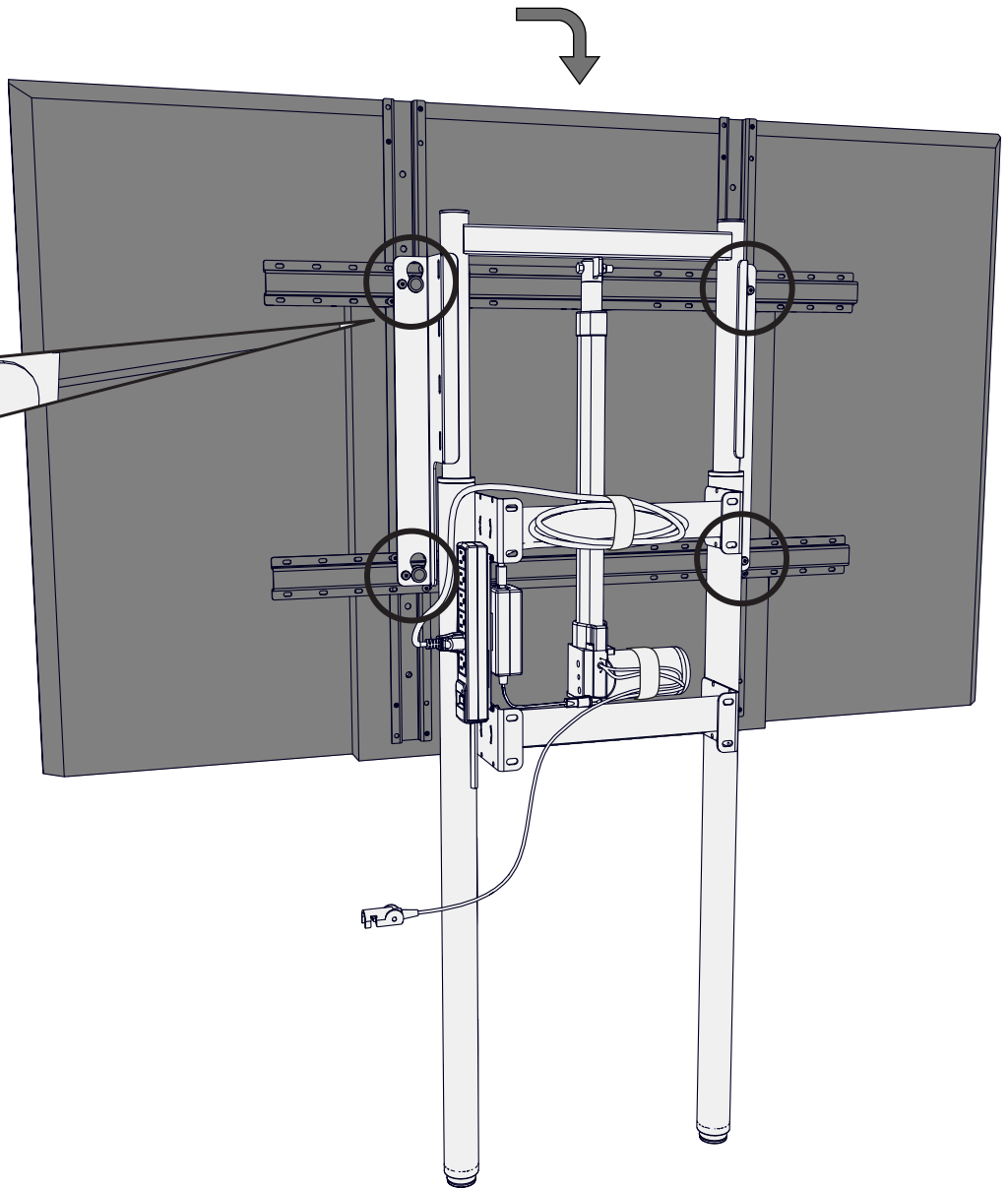
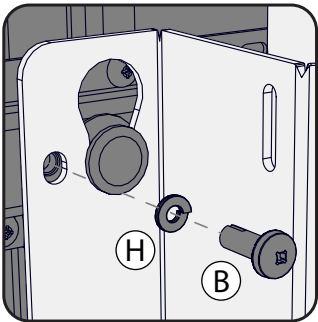

You will need: (Not to Scale)

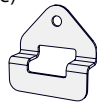

Remote Hanger Bracket
1x



Electric Lift Remote
1x



Hammer Drill
1x

Mount The Remote Hanger Bracket On Wall & Connect Remote

! Use hardware recommended for your wall type. See Page 6 for recommended hardware. **FASTENERS ARE NOT INCLUDED.**

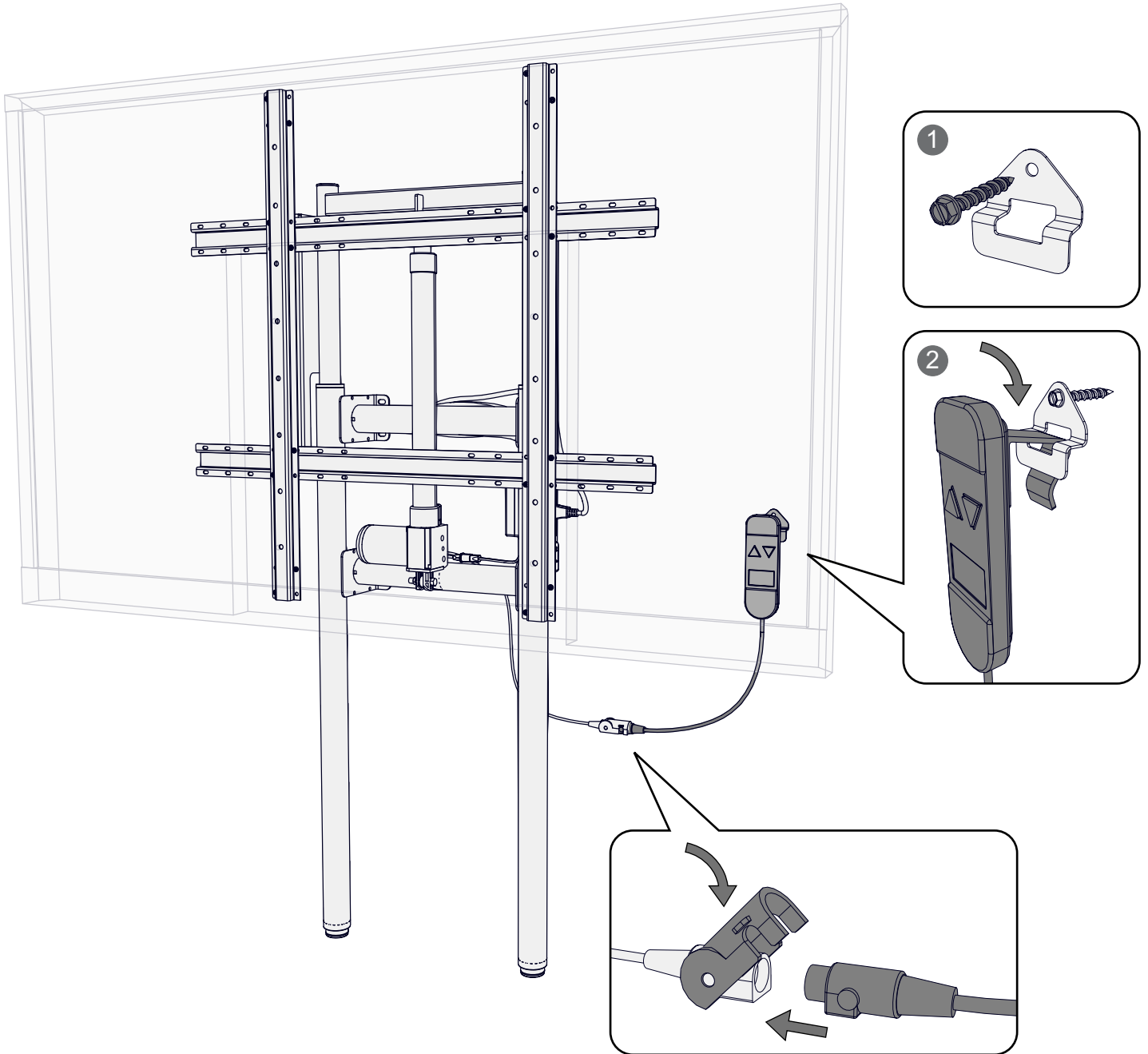
Care And Maintenance

To ensure continued smooth operation of your wall mount, follow these instructions to lubricate the outer bushings every 6 months:

- 1 Raise the board to its highest position.

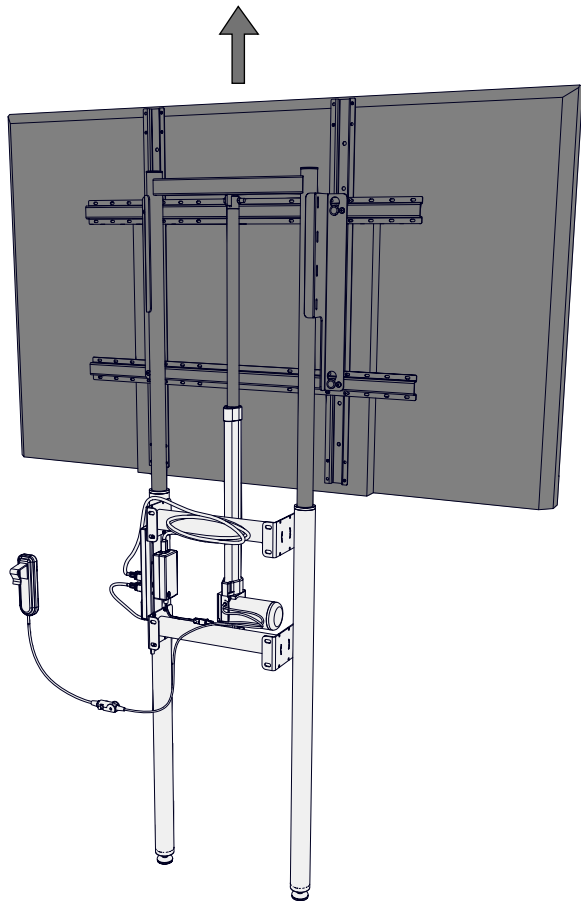

- 2 Apply a generous bead of Petroleum Jelly all around the top of both bushings, pressing some in the gap between the frame and bushing.

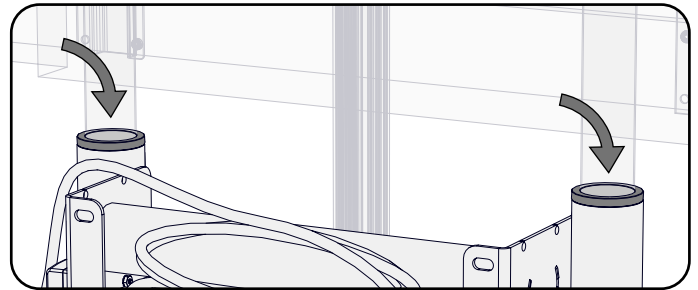

- 3 Lower the unit back down to its lowest position.

