



## Assembly Guide

Check out our other products online at [www.copernicused.com](http://www.copernicused.com)

For assistance, please contact us by telephone at **1-800-267-8494** or email at [info@copernicused.com](mailto:info@copernicused.com).

Have your packing slip ready for reference.

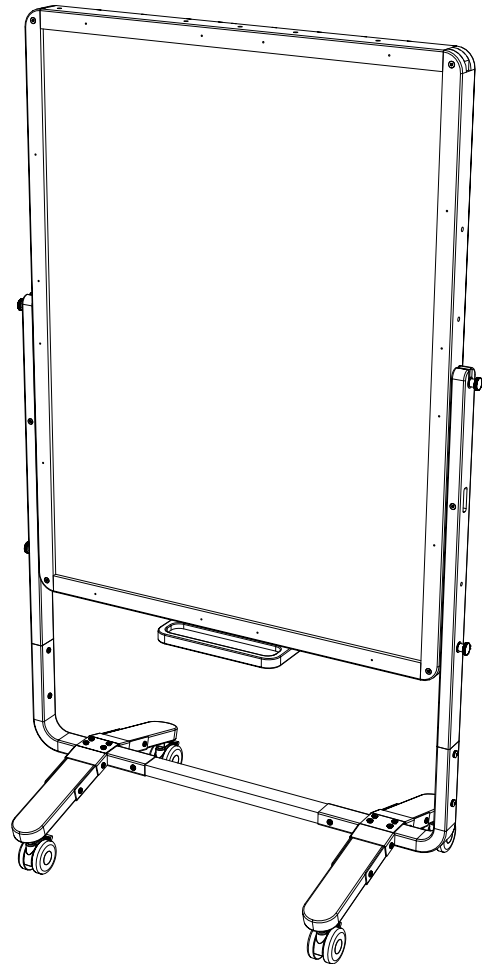
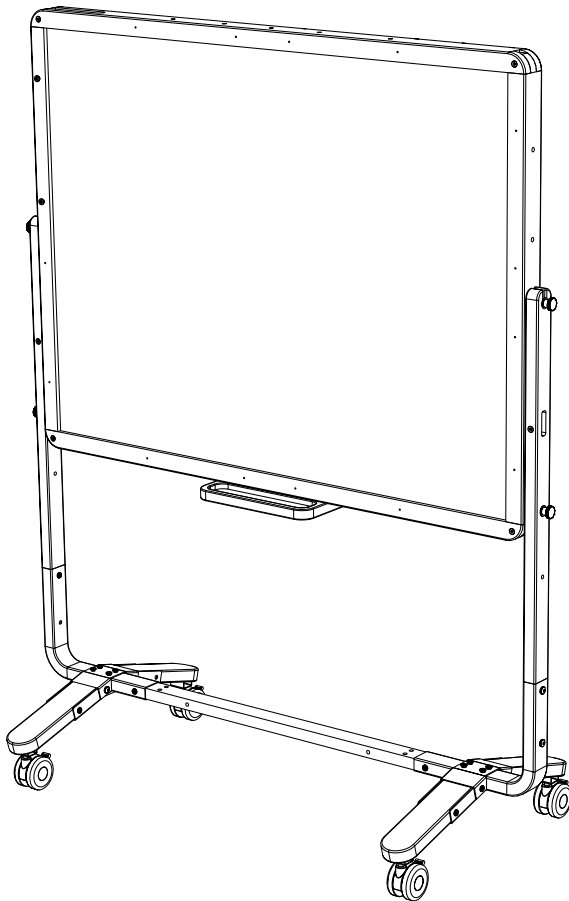

# Customer Service & Warranty Information

Dear Educator,

Thank you for purchasing the Collaboration Whiteboard. We hope it meets your expectations and you and your students enjoy using it at your school.

Every day we see and hear stories of teachers going above and beyond to help students thrive. Thank you so much for all you do – you are awesome, and you make a difference.

Thank you for inspiring us.

If you have any questions, concerns or ideas on how we can improve please let us know by contacting our Customer Solutions Ninjas at 1-800-267-8494 or [info@copernicused.com](mailto:info@copernicused.com).

Happy teaching,

Kaylyn Belcourt, President  
[kaylyn@copernicused.com](mailto:kaylyn@copernicused.com)



We do not inherit the earth from our ancestors, we borrow it from our children.

- NATIVE AMERICAN PROVERB

Change is the end result of all true learning.

- LEO BUSCAGLIA

What you leave behind is not what is engraved in stone monuments, but what is woven into the lives of others.

- PERICLES

Education is the most powerful weapon which you can use to change the world.

- NELSON MANDELA

## For missing parts and other issues regarding your product:

Please contact Customer Service, where we will be happy to help.  
Telephone: 1-800-267-8494, Monday - Friday 8:00am - 4:30 pm EST  
Email: [info@copernicused.com](mailto:info@copernicused.com)

**Need Support?  
Have a Question?**



Email [Customer Service](mailto:CustomerService)

**Check out some of our  
other great products!**



[www.copernicused.com](http://www.copernicused.com)

**Lifetime**  
All Components  
Warranty

### Register your Product

Registering your warranty ensures we have all the information we need to make any future warranty claims quick and easy. Please visit [www.copernicused.com/warranty](http://www.copernicused.com/warranty) and complete the form within 10 business days from product assembly. By registering your product, you will be entered into a draw to win Copernicus product.

**5 Year**  
Whiteboard  
Warranty

### Make a Warranty Claim

We offer a Lifetime Warranty on almost everything we make. Please call **1-800-267-8494** or email [info@copernicused.com](mailto:info@copernicused.com) to start your warranty claim. Proof of purchase will be required upon warranty claim (i.e. copy of invoice).

### Replace your Whiteboard

Have a well-used whiteboard that needs replacing? Our whiteboards carry a five-year warranty and replacement parts program after the warranty period. Please call **1-800-267-8494** or email [info@copernicused.com](mailto:info@copernicused.com) to get a new whiteboard for your Copernicus product!

# Tips for Assembly

## Before You Begin:

- Lay out and identify all of the included parts.
- The hardware has been packed according to step.
- Read the assembly guide over once to familiarize yourself with them.

## As You Assemble the Unit:

- Follow the steps in sequence.
- Before beginning each step, find the part(s) that you need for that step.
- The title of each step states what you will be doing. Review the text and the pictures as you build the unit.

## Watch for These Helpful Symbols:



2-Person Task

For safety, please have someone help you when working on steps displaying this symbol.



The symbol denotes a step needing extra attention to ensure it is done correctly.



# Important Information! Warning!

Please read the warnings below for important safety information regarding your product. Failure to read these warnings or to follow the instructions below could result in personal injury or damage to your product that could void your warranty.



### Small Parts

In its unassembled state, this product contains parts that can be hazardous to small children. This product should be assembled by an adult.



### Adult Supervision

This product is to be used under the supervision of an adult.



### No Maintenance

This product does **NOT** require maintenance. Repairs should only be performed by authorized personnel. Please contact customer service if repairs are required.



### Climb Hazard

Do not climb on, hang from or suspend objects from any components of your product unless otherwise specified.



### Indoor Use Only

This product is intended for indoor commercial use only. To reduce the risk of fire or electric shock, do not expose this product to rain or moisture. The internal components are not sealed from the environment.

# Parts

Before beginning, you should have:

**CWB-0**

Latch Upright (52029) **1x**

Upright (52030) **1x**

Marker Ledge (52027) **1x**

Foot (52028) **2x**

Caster (4100311) **4x**

Stretcher (52026) **1x**

4mm Allen Key (432810) **2x**

Caster Wrench (32129) **1x**

**In CWB2-0**

**CWB-1**

Whiteboard **1x**

**Hardware**  
Actual Size

**A** M6 Knob (430375) **4x**

**B** M6 x 55mm Screw (43251) **2x**

**C** M6 x 45mm Screw (43245) **8x**

**D** M6 x 25mm Screw (43229) **2x**

**E** M6 x 40mm Barrel Nut (432721) **2x**

**F** M6 Lock Washer (43273) **10x**

**G** M8 Lock Washer (43274) **6x**

**H** 13mm Washer (432731) **2x**

**I** 19mm Washer (432733) **4x**

1

2-Person Task

Actual Size:

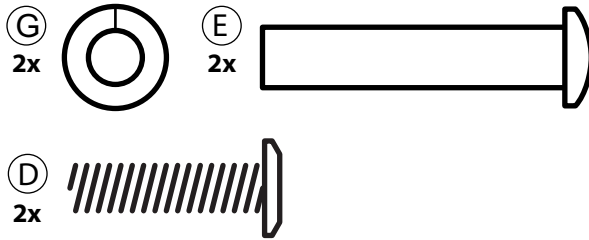

You will need: (Not to Scale)

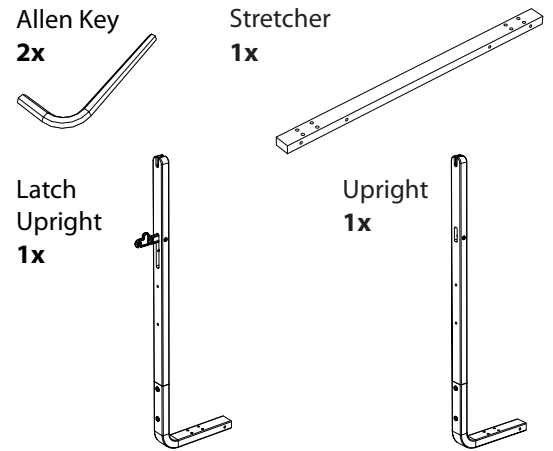

### Install stretcher

1 Choose board orientation

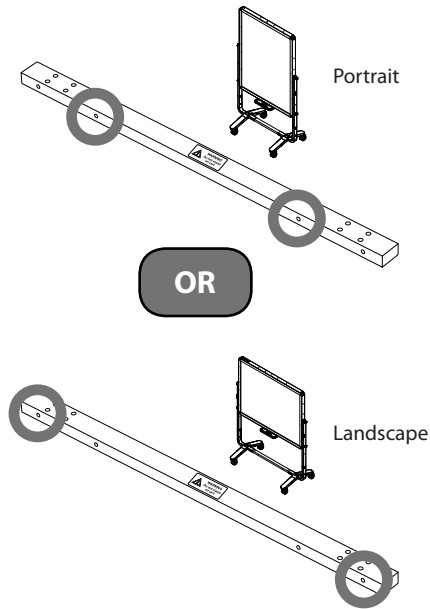

**WARNING**  
Do not stand on cart

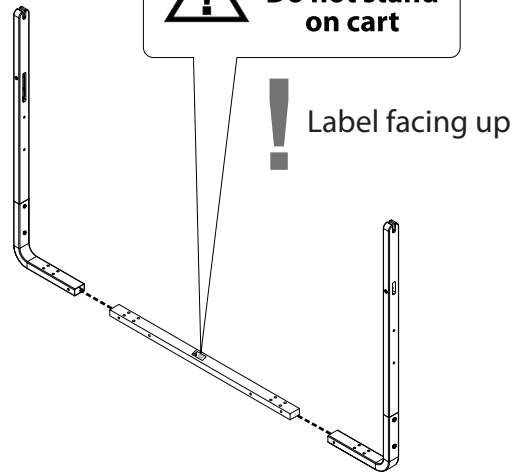

2

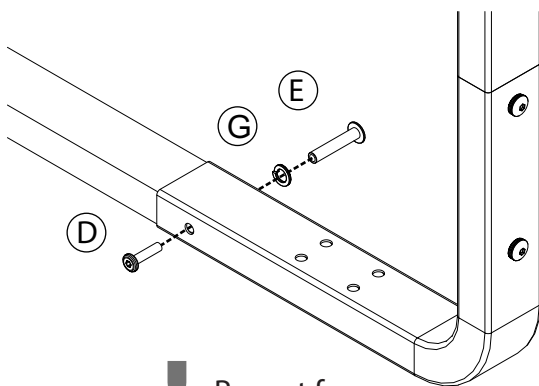

! Repeat for other side

3

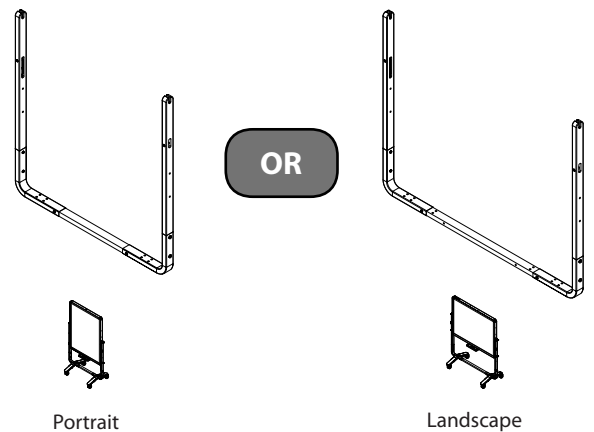

2

You will need: (Not to Scale)

Foot  
2x

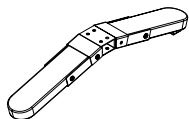

Allen Key  
2x



### Remove caps from feet

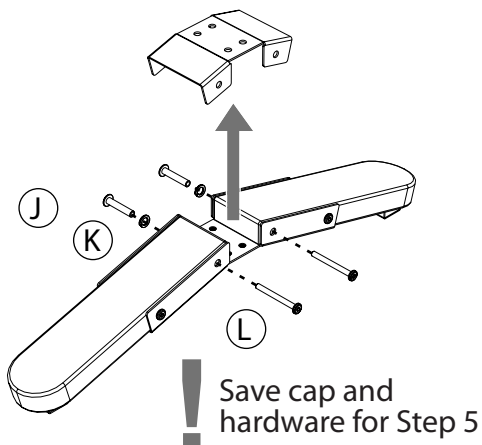

3

Actual Size:



G  
4x

You will need: (Not to Scale)

Foot  
2x

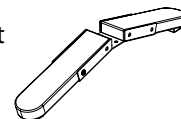

### Install casters

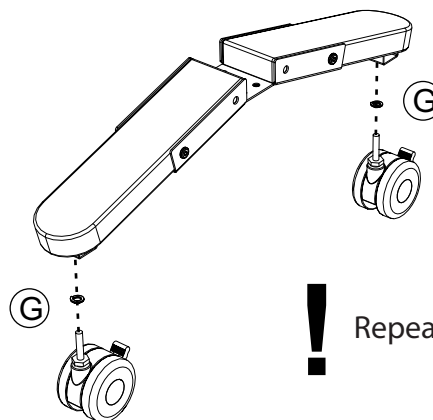

Caster Wrench  
1x

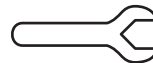

Caster  
4x



4

You will need: (Not to Scale)



2-Person Task

Foot  
2x

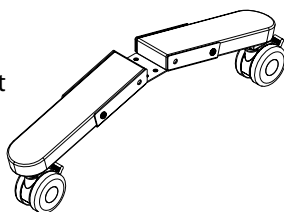

Foot  
2x

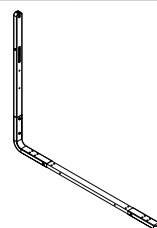

### Install frame to feet

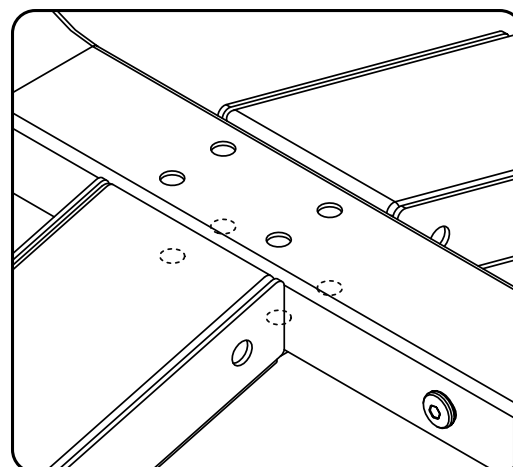
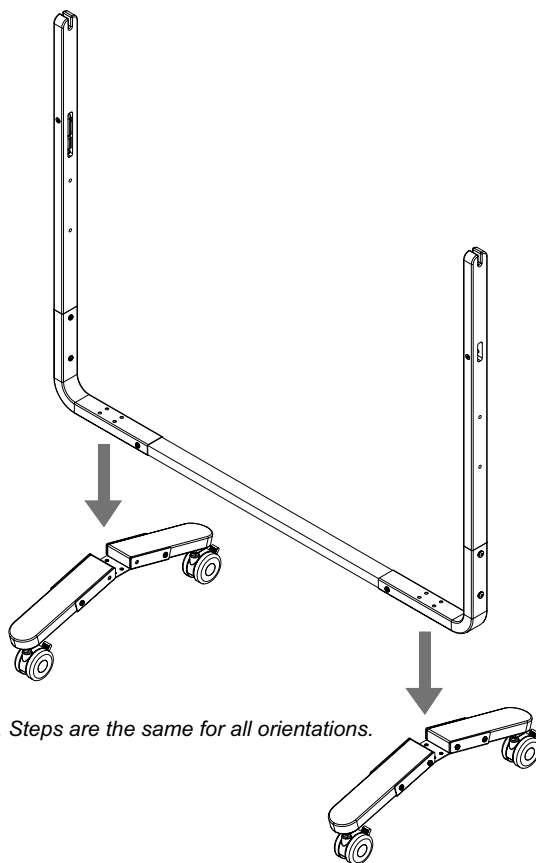

! Ensure that the holes on the feet and corners are aligned

5

Actual Size:

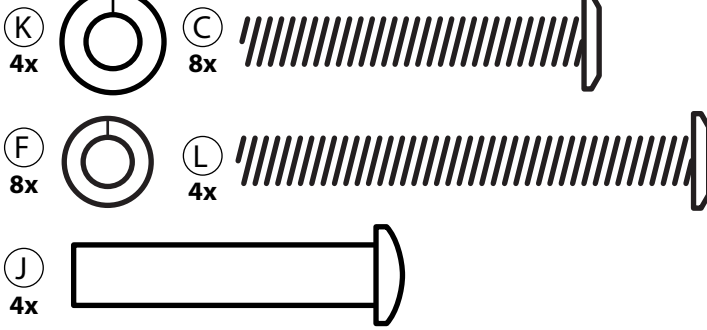

You will need: (Not to Scale)

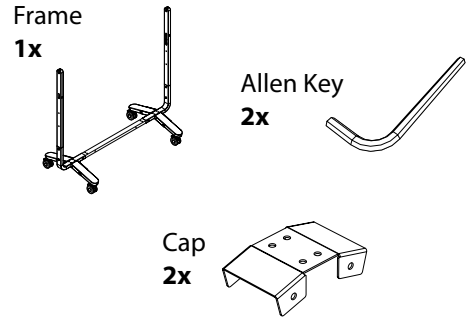

### Fasten caps to feet

1 Install cap hardware on both sides of easel. Do not fully tighten until after Step 5-2.

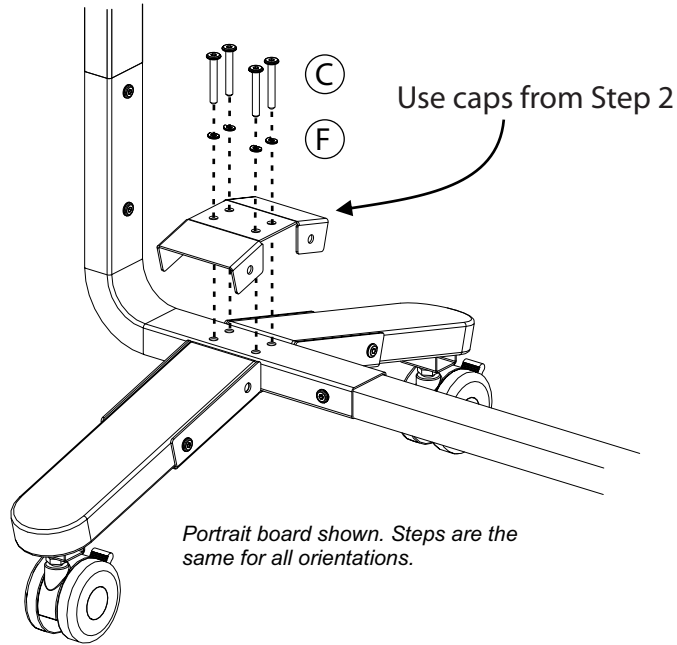

2 Install hardware from Step 2. Repeat on other side of easel.

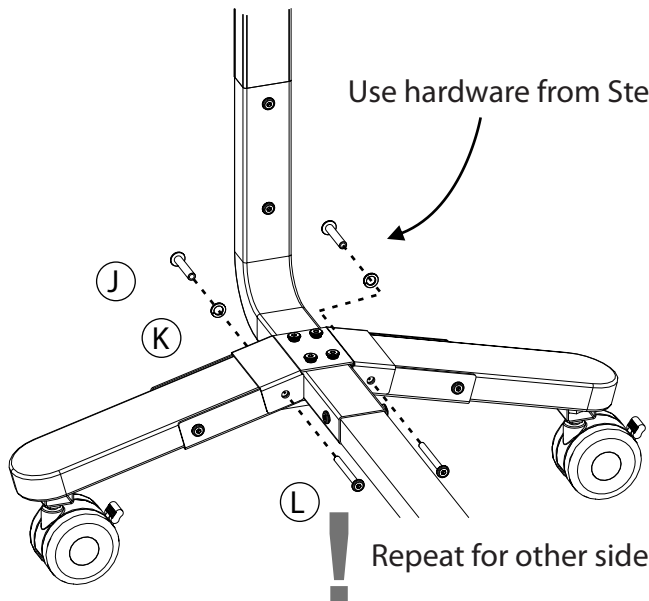

**!** Check that all hardware has been tightened.

6

Actual Size:

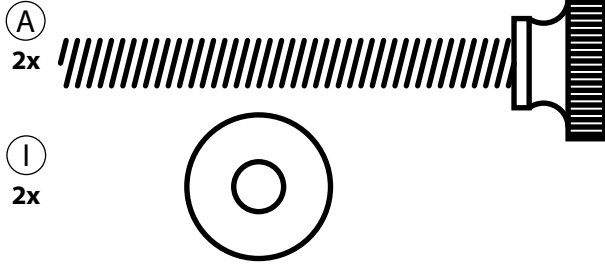

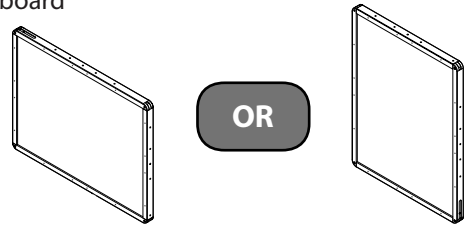

You will need: (Not to Scale)

Whiteboard  
1x

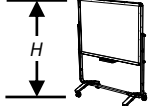
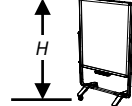

## Install hardware

### 1 Choose board height position

Height Setup	Board Orientation	
	Landscape	Portrait
High <i>Recommended for 9YO and older</i>	 67-3/4" (172cm)	 74" (186.5cm)
Low <i>Recommended for 8YO and younger</i>	 55-1/2" (141cm)	 61-3/4" (157cm)

*These are recommendations only and may not be accurate for everyone. If the recommended height position is not comfortable for the end users, try the other board height position.*

### 2 Install hardware into the appropriate location

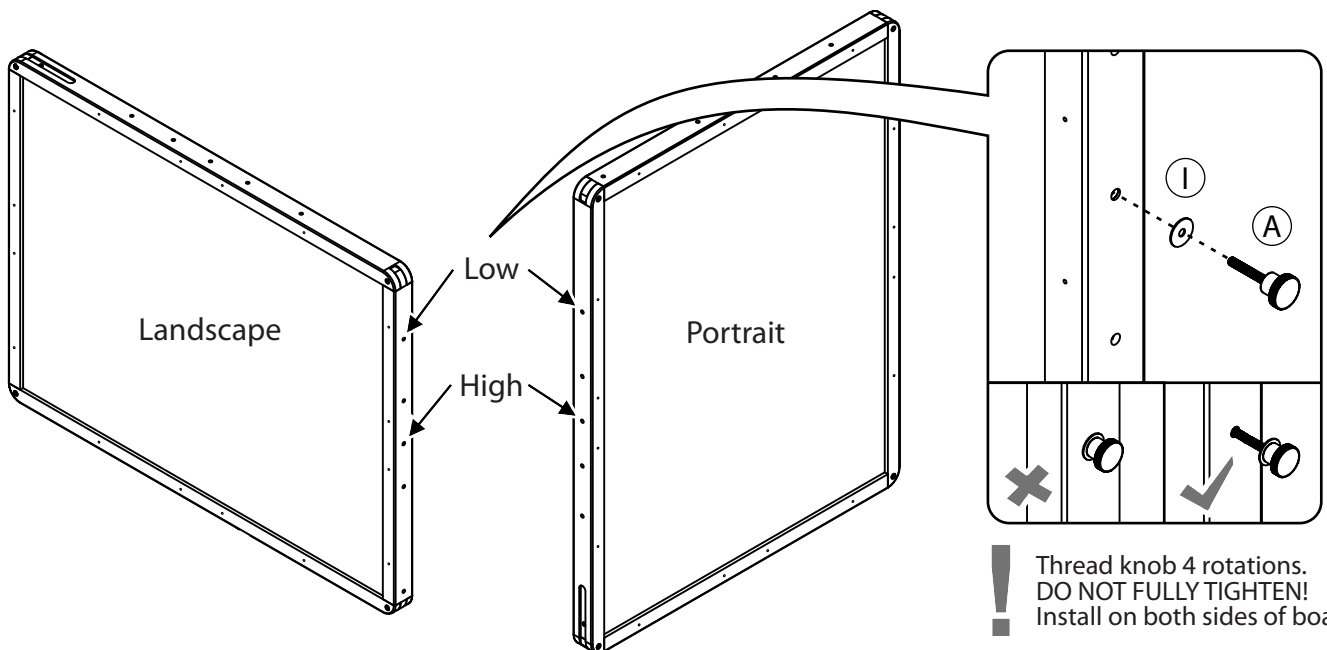



7

You will need: (Not to Scale)



2-Person Task

Whiteboard  
1x

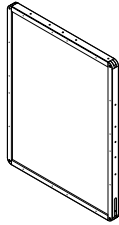

OR

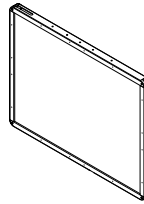

### Install whiteboard

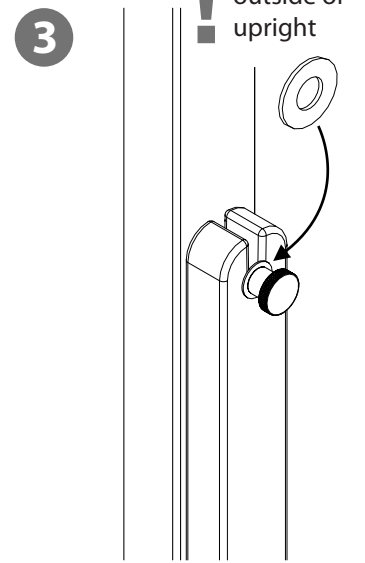
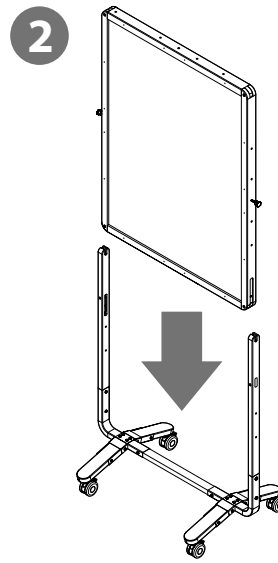
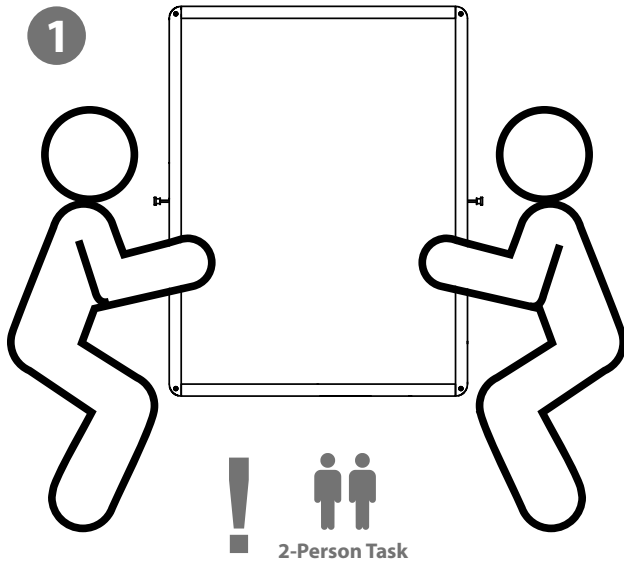

Portrait board shown. Steps are the same for all orientations and heights.

8

Actual Size:

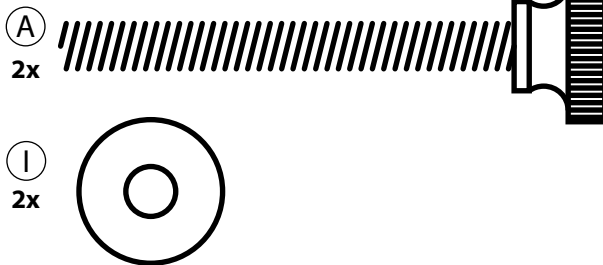

You will need: (Not to Scale)

Whiteboard  
1x

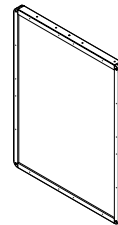

OR

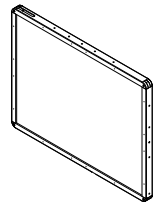

### Install hardware

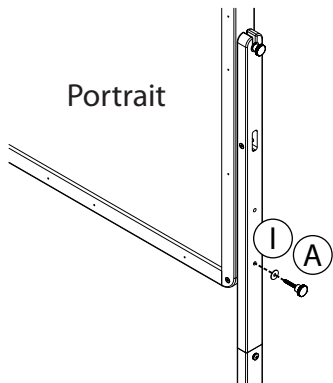

OR

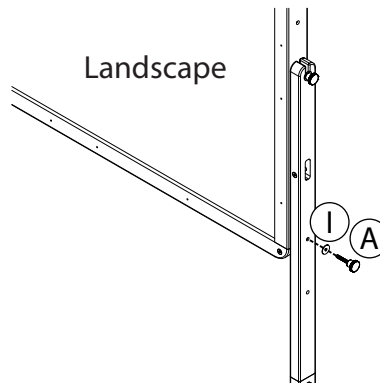

! Install on both sides.  
Tighten all knobs fully

9

Actual Size:



You will need: (Not to Scale)

Marker Ledge

1x

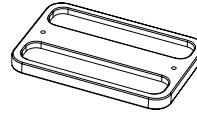

Allen Key

1x



## Install marker ledge

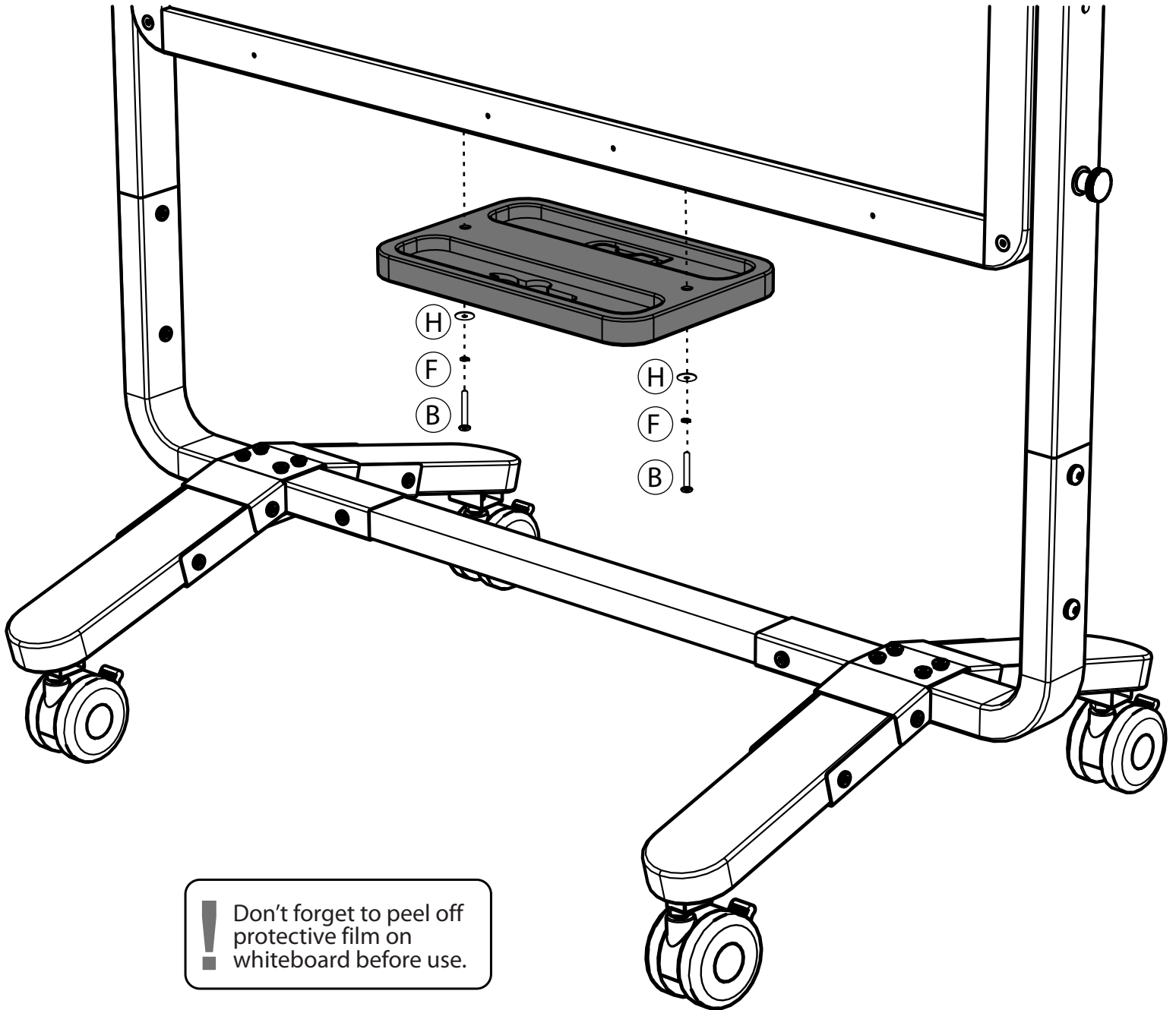

# Features

## Tool Storage

Store tools in marker ledge. Inspect casters and hardware every 3 months. Tighten as needed.

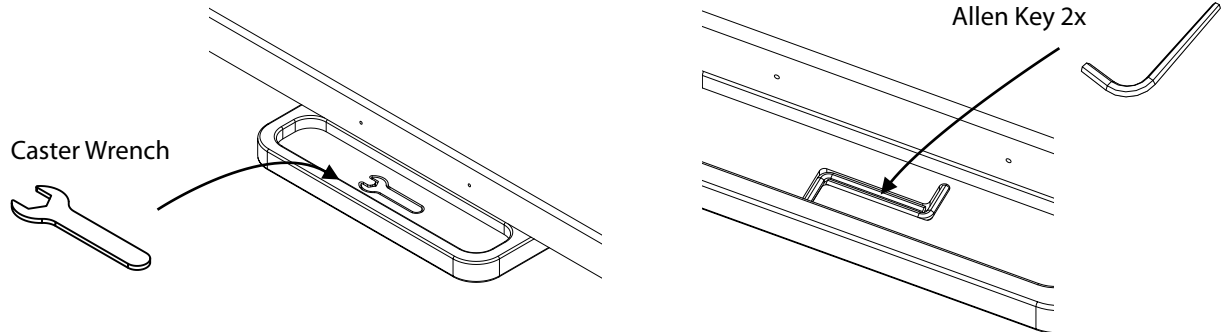

## Whiteboard Partition

The Collaboration Whiteboard can be joined to additional Collaboration Whiteboards to create a whiteboard partition. Boards can be linked regardless of orientation and height setups.

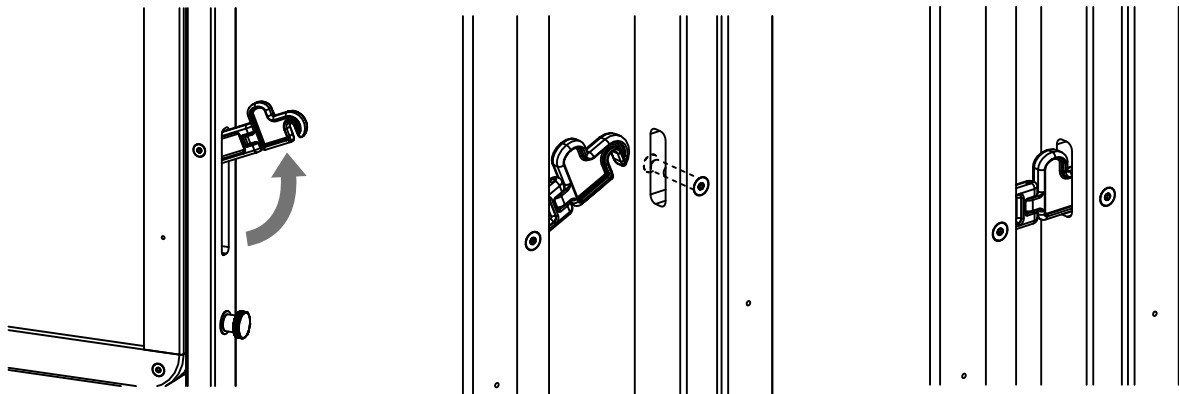

**1** Lift hook from Easel 1

**2** Align hook with opening on Easel 2 and lower over bar

**3** Finished

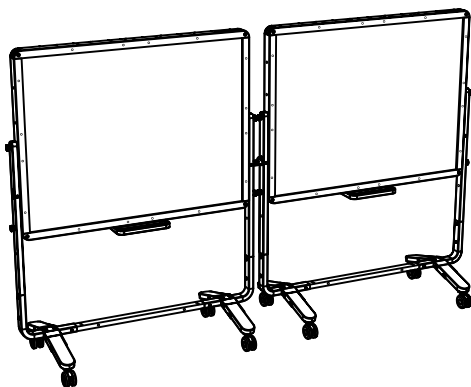

**4** Arrange whiteboards in straight or in angled partition. Lock casters once in position.

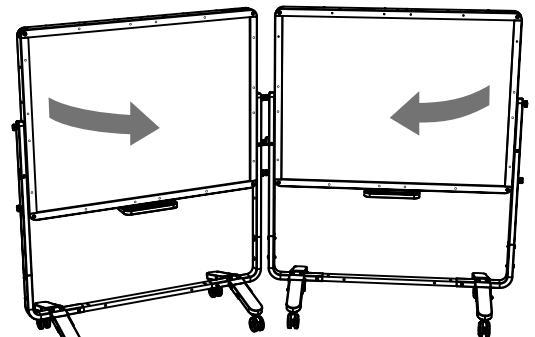
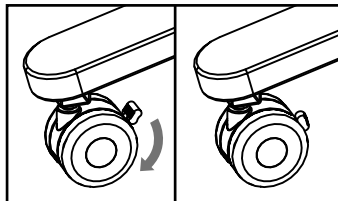

*To make angled partition, unlock casters and bring boards together.*