

**iRover<sup>2</sup> for Interactive Flat Panels**

Model: IFP500

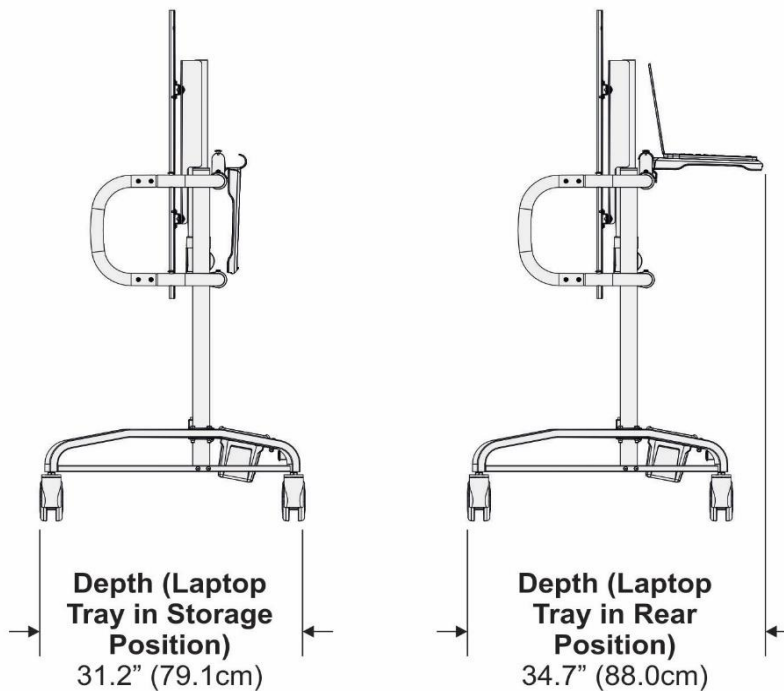
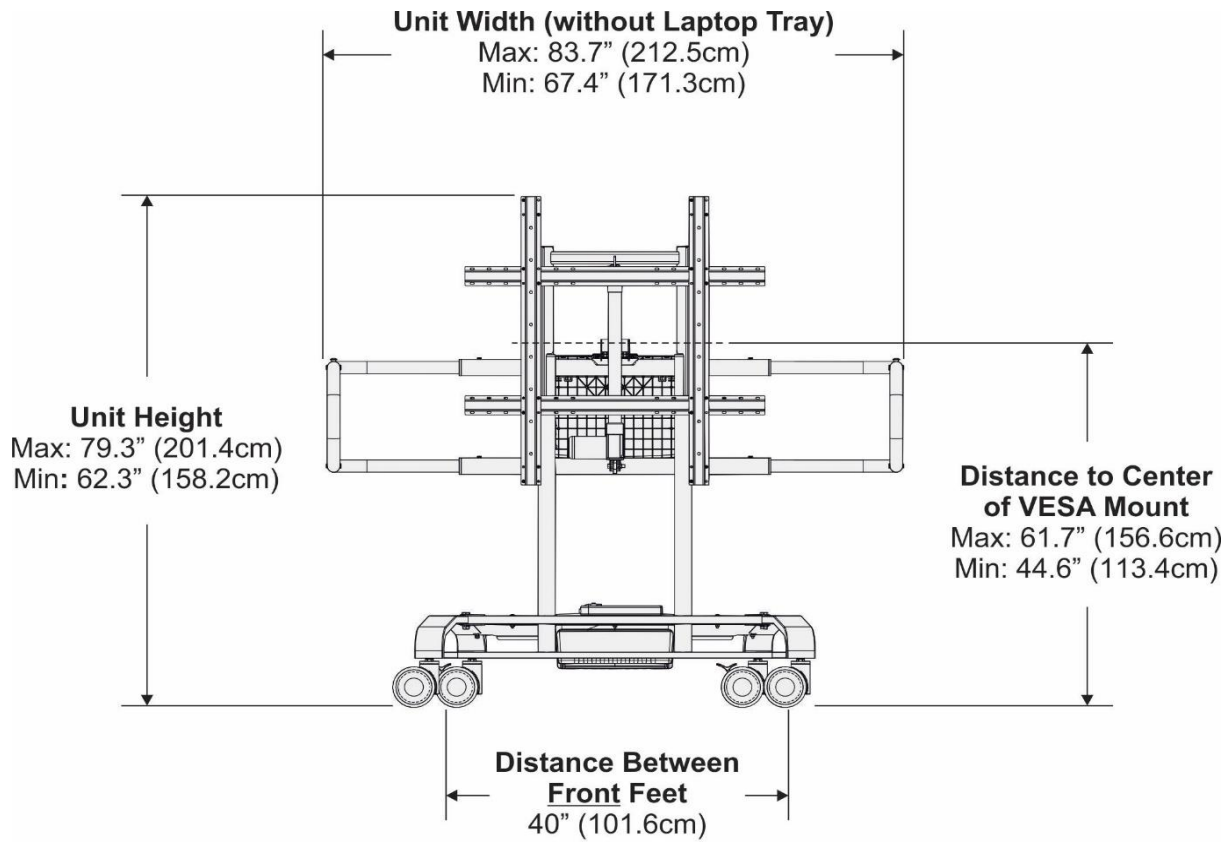

All dimensions ± 1/8" (0.3cm).  
All weights ± 8 oz (250g).

**iRover<sup>2</sup> for Interactive Flat Panels**

Model: IFP500

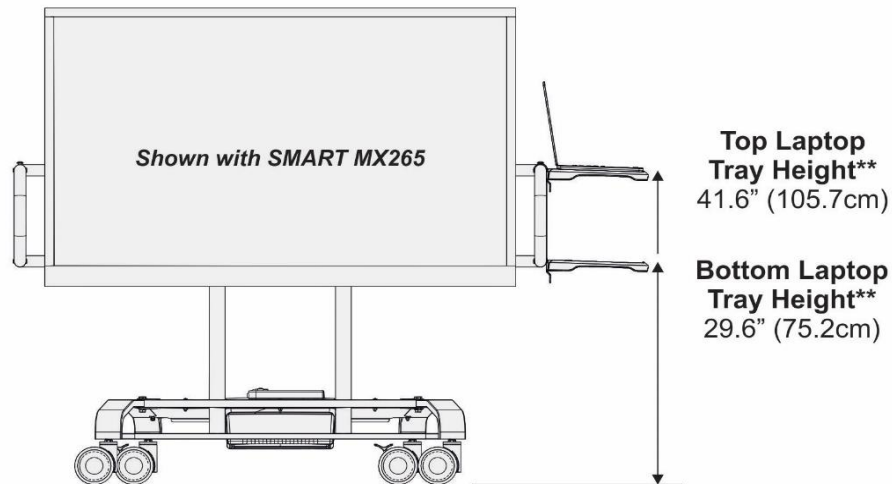
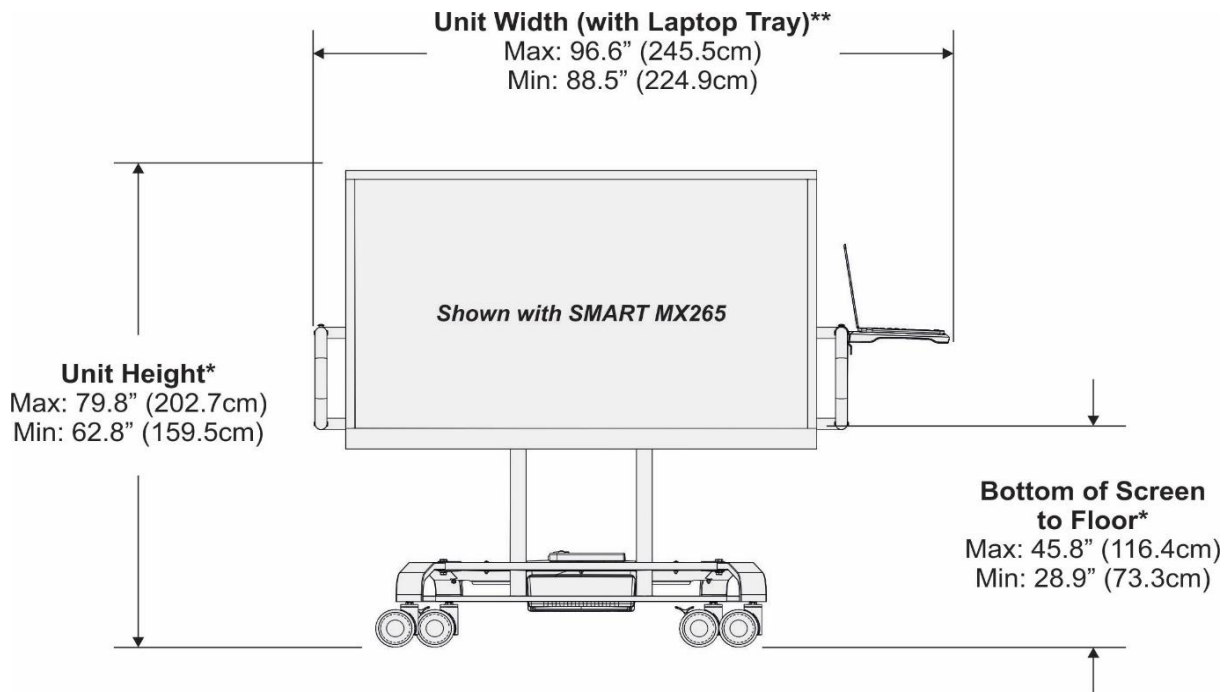

(\*) values are approximate and will vary depending on your flat panel.  
(\*\*) Laptop Tray can be installed on both handles.

## iRover<sup>2</sup> for Interactive Flat Panels

Model: IFP500

### Warranty:

5 year electric lift warranty

Lifetime frame, tub and power strip warranty

### Physical Specifications:

62.3" H x 69.9" W x 31.2" D (158.2cm H x 176.7cm W x 79.1cm D)

- Measurements taken with laptop tray in stored position for transporting.
- Measurements do not include installed flat panel.

### Laptop Tray Compatibility:

- Top surface measures 14.9" W x 11.1" D (38.0cm W x 28.2cm D)
- Supports a max weight of 20lbs.

### Flat Panel Compatibility:

Commonly supported flat panels include: SMART, Promethean, Clever Touch, Clear Touch and others. Spacers and longer screws are provided for flat panels that do not have a flat back, like Promethean.

### Flat Panel Mount:

This unit comes with its own VESA flat panel mount.

Supported Screen Size: 50"- 86"

Supported VESA: 300 x 200 (min)

800 x 700 (max)

Max Weight: 250lbs (90.7kg)

### Power Strip Specifications:

Outlets: 6 Right-angle NEMA 5-15R

Size: 1-1/2" H x 9-5/8" W x 1-3/4" D (4.0cm H x 24.4cm W x 4.5cm D)

AC Rating: 125V 15A 60Hz

Cable: 14-gauge thickness, 2.5m (8 ft.) length

Conformance: cETLus

Switch: On/Off with built-in 900J surge protector

### Electric Lift Specifications:

Max Load: 2000N (449.6lbf pound-force)

Duty Cycle: 2 Minutes ON, 18 Minutes OFF

**iRover<sup>2</sup> for Interactive Flat Panels**

Model: IFP500

**Carton Size & Weights:**

	<b>Part No.</b>	<b>Carton Size</b> (outer dimensions)	<b>Carton Weight</b>	<b>Shipping Size</b> (cubic feet)	<b>Shipping Weights</b>
<b>IFP500</b>	IFP500-0	40" H x 40" W x 4-1/2" D 102cm H x 102cm W x 12cm D	37lbs 16.8kg	4.63	41lbs 18.6kg
	IFP500-1	47" H x 26-1/2" W x 4" D 120cm H x 68cm W x 11cm D	32.5lbs 14.7kg	2.94	26lbs 11.8kg
	IFP500-2	38" H x 17" W x 13" D 97cm H x 44cm W x 33cm D	57lbs 25.9kg	4.86	43lbs 19.5kg

**Copernicus Educational Products**

USA | P.O. Box 248 | Buffalo, NY | 14225

CANADA: R.R. #3, 8194 County Road 109 | Arthur, ON | N0G 1A0

P 1 800 267 8494 | E info@copernicused.com

Copernicus Educational Products is not responsible for printing errors. Copernicus reserves the right to change or modify pricing and products specifications with or without prior notification. Illustrations and descriptions may not be exactly as shown. No part may be reproduced by any means without prior authorization of Copernicus Educational Products Inc. All rights reserved. 2015 ©